

P-touch **PRO**



MODEL PT-9400

USER'S GUIDE



- Read this User's Guide before you start using your P-Touch.
- Keep this User's Guide in a handy place for future reference.

brother®

PREFACE

Thank you for purchasing this P-touch!

With your new P-touch, you can create labels for any purpose. Select from a variety of frames, fonts and character styles to design beautiful custom labels. In addition, the many pre-formatted templates available make label- and stamp-making quick and easy.

Installing the P-touch Editor software on your computer will provide you with many more illustration and layout tools to design labels, which can then be printed on your P-touch.

You can print professional-looking labels in no time. The quality and performance of this P-touch make it an extremely practical machine to meet all your labelling needs.

Although this P-touch is easy to use, we suggest that you read this User's Guide carefully before starting. Keep this manual nearby for future reference.

FCC NOTICE

This equipment has been tested and found to comply with the limits for a Class B digital device, pursuant to Part 15 of the FCC Rules. These limits are designed to provide reasonable protection against harmful interference in a residential installation. This equipment generates, uses, and can radiate radio frequency energy and, if not installed and used in accordance with the instructions, may cause harmful interference to radio communications. However, there is no guarantee that interference will not occur in a particular installation. If this equipment does cause harmful interference to radio or television reception, which can be determined by turning the equipment off and on, the user is encouraged to try to correct the interference by one or more of the following measures:

Reorient or relocate the receiving antenna.

Increase the separation between the equipment and receiver.

Connect the equipment into an outlet on a circuit different from that to which the receiver is connected.

Consult the dealer or an experienced radio/TV technician for help.

The enclosed interface cable should be used in order to ensure compliance with the limits for a Class B digital device.

Changes or modifications not expressly approved by Brother Industries, Ltd. could void the user's authority to operate the equipment.

This product is covered by one or more of the following patents.

USP4839742

USP4983058

EP315369

GB2223740

USP4922063

USP5009530

EP322918

USP4927278

USP5069557

EP322919

USP4966476

USP5120147

USP4976558

CONTENTS

QUICK REFERENCE

Chapter 1

Before You Start..... 1

EXAMPLES OF WHAT YOU CAN MAKE WITH THIS P-TOUCH2

GENERAL DESCRIPTION.....4

<i>Features</i>	4
<i>LCD display</i>	5
<i>Menus</i>	5
<i>Keyboard</i>	6

Chapter 2

Getting Started..... 7

PRECAUTIONS8

<i>Connecting the power supply cord</i>	9
<i>Installing a TZ tape cassette</i>	10
<i>Turning on & off the P-touch</i>	11

Chapter 3

Functions 13

<i>Performing basic operations</i>	14
<i>Entering text</i>	15
<i>Editing text</i>	21
<i>Formatting</i>	24
<i>Storing and recalling files</i>	46
<i>Printing</i>	49
<i>Setting display features</i>	57

Chapter 4

Using Labels and Stamps.....	61
<i>Laminated tape</i>	62
<i>Stamp film</i>	62
ERROR MESSAGE LIST	65
TROUBLESHOOTING	70
MACHINE SPECIFICATIONS.....	73

Appendix	75
<i>Symbols</i>	76
<i>Special barcode characters</i>	80
<i>Fonts</i>	80
<i>Sizes and widths</i>	81
<i>Type styles</i>	82
<i>Framing and shading patterns</i>	83
<i>Background designs</i>	84
<i>Pre-set templates</i>	85
<i>Template text styles</i>	89
<i>Text transformation styles</i>	90
INDEX	91
ACCESSORIES.....	93

QUICK REFERENCE

Entering text

Adding a space	Space bar
Adding a capital letter	Shift + desired character
Adding a series of capital letters	Caps → Type character
Adding an accented character	Alt → Type character → [←] or [→] to select → [↵] New Block
Adding a symbol	a) [Symbol] → [↑] or [↓] to select SYMBOL NO. → [↵] New Block → [↑] or [↓] to select (or type) symbol number → [↵] New Block b) [Symbol] → [↑] or [↓] to select symbol category → [↵] New Block → [←], [→], [↑], or [↓] to select symbol number → [↵] New Block
Adding a new line	[↵] New Block
Adding a new block	[Code] + [↵] New Block
Adding a barcode	[Barcode] → Type barcode data → [↵] New Block
Adding a special character to the barcode	[Barcode] → [Symbol] → [↑] or [↓] to select special character → [↵] New Block
Changing a barcode parameter	[Barcode] → [Format] → [↑] or [↓] to select parameter → [→] → [↑] or [↓] to select setting → [↵] New Block → [↵] New Block

Editing text

Zooming in and out	[Zoom Image]
Deleting text	[Back Space] Clear
Clearing all of the text and formats	[Code] + [Back Space] Clear → [↑] or [↓] to select TEXT & FORMATS → [↵] New Block
Clearing only the text	[Code] + [Back Space] Clear → [↑] or [↓] to select TEXT ONLY → [↵] New Block
Selecting an area of the text	[Area All] → [←], [→], [↑] or [↓] to select text
Selecting all of the text	[Code] + [Area All]
Copying text	[Area All] → [←], [→], [↑] or [↓] to select text → [Copy & Paste]
Pasting text	Copy text → [←], [→], [↑] or [↓] to position cursor → [Copy & Paste] → [↑] or [↓] to select OK → [↵] New Block



Formatting text

Changing the font	Font
Changing the character size	Size
Changing the character width	Width
Changing the character style	Style
Changing the italic setting	Italic
Changing the line effects	A / A
Changing the vertical printing setting	Vert
Changing the label length	Format → ↑ or ↓ to select LENGTH → → → ↑ or ↓ to select (or type) setting → ← New Block
Changing the margins	Format → ↑ or ↓ to select MARGIN → → → ↑ or ↓ to select setting → ← New Block
Changing the horizontal alignment	Format → ↑ or ↓ to select H.ALI → → → ↑ or ↓ to select setting → ← New Block
Changing the pitch	Format → ↑ or ↓ to select PITCH → → → ↑ or ↓ to select setting → ← New Block
Changing the background	a) Format → ↑ or ↓ to select BACK → → → ↑ or ↓ to select design → ← New Block b) Format → ↑ or ↓ to select BACK → → → ↑ or ↓ to select SMALL or LARGE → ← New Block → type text → Font to select font and ← New Block → ← New Block

Using a template

Creating a label or stamp from a template	a) Templ → ↑ or ↓ to select TEMPLATE NO. → ← New Block → ↑ or ↓ to select (or type) template number → ← New Block → Type line of text and ← New Block → Continue with 1, 2, 3, 4 or 5 b) Templ → ↑ or ↓ to select template category → ← New Block → ↑ or ↓ to select template number → ← New Block → Type line of text and ← New Block → Continue with 1, 2, 3, 4 or 5
1 Changing the style of the template	↑ or ↓ to select CHANGE STYLE → ← New Block → → → ↑ or ↓ to select setting → ← New Block → ← New Block
2 Editing the template text	↑ or ↓ to select CONTINUE → ← New Block → Change the text → ← New Block
3 Printing a template other than one from the STAMP category	↑ or ↓ to select PRINT → ← New Block → → → ↑ or ↓ to select OK → ← New Block



Changing the print options (for a template other than one from the STAMP category)	or to select PRINT → → or to select OPTION → → Continue with 6, 7, 8, 9, O, A or B
4 Printing a template from the STAMP category	or to select PRINT → → or to select PRINT STAMP →
Printing an ID label (for a template from the STAMP category)	or to select PRINT → → or to select PRINT LABEL →
5 Storing the template text	or to select FILE → → or to select SAVE AS or SAVE → → or to select file name → Type file name →













































Storing, recalling deleting text files

Saving a file that has not been saved before	→ or to select SAVE AS → → or to select file number → Type file name →
Saving a previously saved file	→ or to select SAVE → → Edit file name →
Recalling a previously saved file	a) → or to select OPEN → → or to select file number → b) → or to select OPEN → → Type file name → → or to select file →
Deleting a previously saved file	a) → or to select DELETE → → or to select file number → → or to select OK → b) → or to select DELETE → → Type file name → → or to select file →

Printing text

Previewing the label appearance	+
Feeding and cutting 1" (25 mm) of tape	
Printing using the current print options	→ or to select OK →
Changing the print options	→ or to select OPTION → → Continue with 6, 7, 8, 9, O, A or B
6 Printing many copies	or to select COPIES → → or to select (or type) number →



<p>7 Printing many copies while increasing selected text</p>	<p>  or  to select NUMBER →  →  ,  ,  or  to select start of numbering field →  →  or  to select end of numbering field →  →  or  to select (or type) number →  </p>
<p>8 Printing a mirror image of the text</p>	<p>  or  to select MIRROR →  →  or  to select ON →  </p>
<p>9 Inverting the printed and unprinted areas</p>	<p>  or  to select INVERT →  →  or  to select ON →  </p>
<p>0 Changing the shape of the text</p>	<p>  or  to select TRANSFORM →  →  or  to select setting →  </p>
<p>A Changing how labels are cut</p>	<p>  or  to select CUT →  →  or  to select setting →  </p>
<p>B Enlarging text and printing it on 2, 3 or 4 labels</p>	<p>  or  to select SPLIT →  →  or  to select setting →  </p>



Before You Start

EXAMPLES OF WHAT YOU CAN

Quickly create a label for a home video by using the **Template** function (⇒ p. 41). If you wish, you can then change the overall style of the text (⇒ p. 43).



With the **New Block** function (⇒ p. 16), your labels can contain sections with different numbers of lines. In this label, part of the text was formatted using a different font (⇒ p. 25) and a different style (⇒ p. 28). In addition, the **Barcode** function makes creating and printing barcodes easy.



Decorate your text using the many frames and shadings (⇒ p. 32). Then, just before printing, use the **TRANSFORMATION** function (⇒ p. 54) to change the shape of the text.



Use the **NUMBER** (numbering) function (⇒ p. 50) to print several numbered labels at one time, without changing the text for each label. You can also invert the printing to make the light parts dark and the dark parts light (⇒ p. 53).

MAKE WITH THIS P-TOUCH

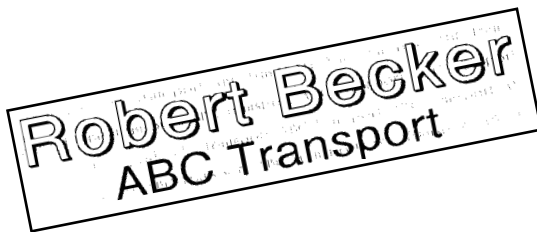

With the **Area** function (⇒ p. 22), you can select certain parts of the text and change their font, size and style (⇒ p. 25–31). Give your label a different look by adding one of the 13 different background designs (⇒ p. 40). The **[SMALL]** and **[LARGE]** background settings allow you to create your own background design.

Create larger labels by enlarging the text and printing it on two, three or four labels, which can then be put together (⇒ p. 56). You can decorate your label using the 475 symbols and pictures available with the **Symbol** function (⇒ p. 17).



Using clear tape and the **MIRROR** function (⇒ p. 52) to print in reverse, this sign for a glass door can be read from the adhesive side. In this example, a warning symbol was added (**Symbol** function ⇒ p. 17), and the entire text was framed using the **Frame/Shading** function (⇒ p. 32). In addition, the label was printed vertically using the **Vertical** function (⇒ p. 31).



	8–12	2–6
Studio 1	Paul	Robert
Studio 2	Robert	Paul

Create a table using the **Frame/Shading** function (⇒ p. 32) to put a box around each line of each block in the text. Then, use the **Area** function (⇒ p. 22) to format the headings of the table.

GENERAL DESCRIPTION

Features

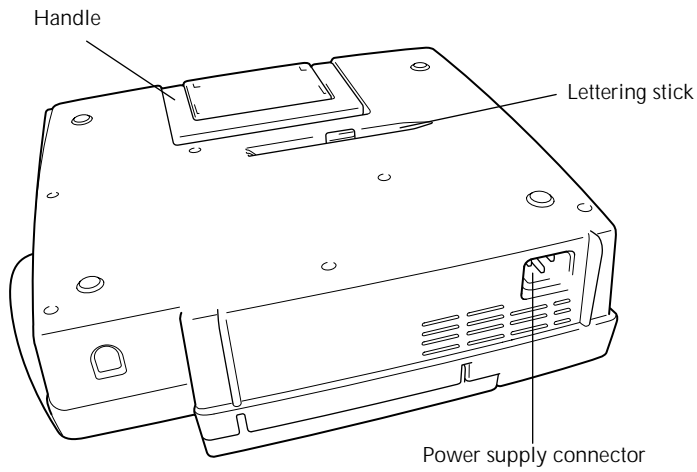
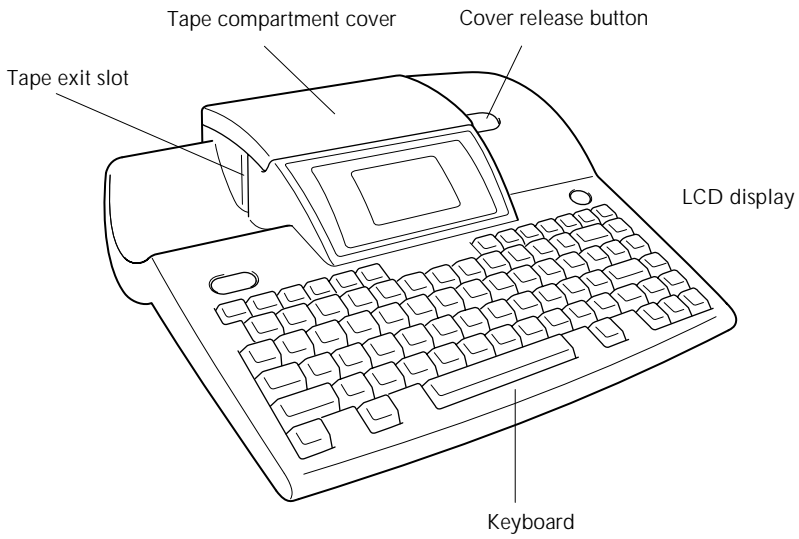

LCD display

Before You Start

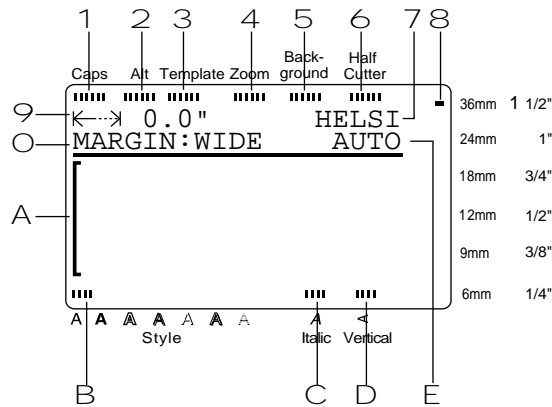

- 1 Caps indicator ⇒ p. 15
- 2 Alt indicator ⇒ p. 15
- 3 Template indicator ⇒ p. 41
- 4 Zoom indicator ⇒ p. 21
- 5 Background indicator ⇒ p. 40
- 6 Half cutter indicator ⇒ p. 55
- 7 Font setting ⇒ p. 24
- 8 Tape width indicator ⇒ p. 10
- 9 Tape length setting ⇒ p. 36
- Margin setting ⇒ p. 37
- A Cursor ⇒ p. 14
- B Style setting indicator ⇒ p. 28
- C Italic setting indicator ⇒ p. 29
- D Vertical printing indicator ⇒ p. 31
- E Character size setting ⇒ p. 25

Menus

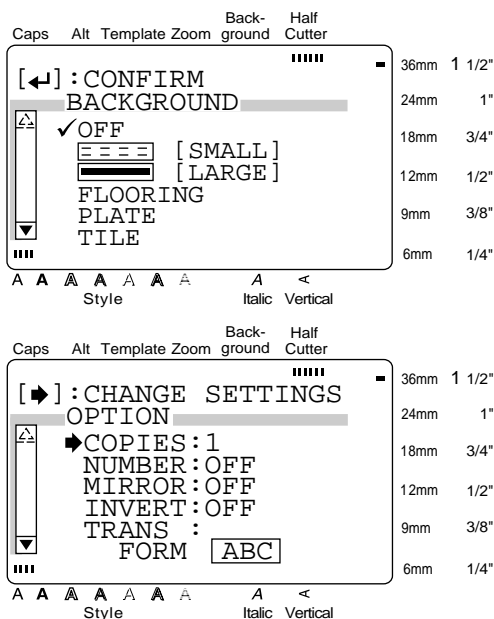

The color of the arrows on the ends of the scroll bar shows whether or not more settings are available. When the arrows are light (☐ and ☐), no more settings are available. When the arrows are dark (▲ and ▼), more settings can be seen by pressing or to move ✓ or → up or down.

In menu where ✓ appears beside a setting or function, pressing confirms the selection.

In menu where → appears beside a function, pressing displays the menu for the selected function. On the other hand, pressing confirms all of the settings displayed in the menu.

Keyboard

Before You Start

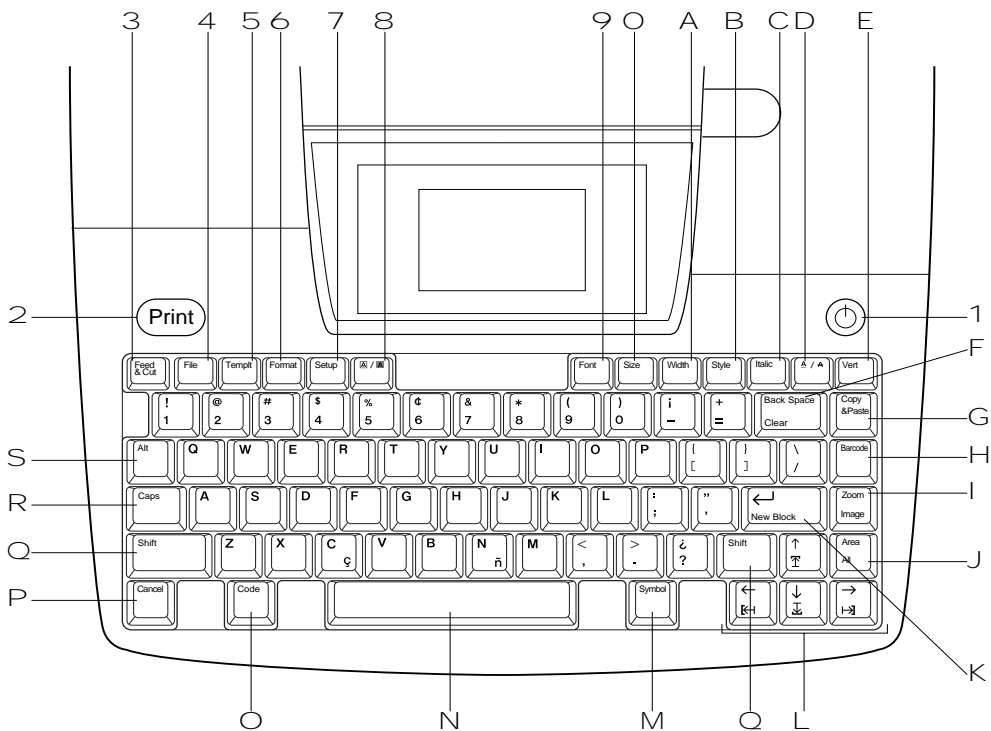

- | | | | |
|---|-----------------------------------|---|----------------------------|
| 1 | ⏻ (power supply) key ⇒ p. 11 | G | Copy & Paste key ⇒ p. 24 |
| 2 | Print key ⇒ p. 49 | H | Barcode key ⇒ p. 18 |
| 3 | Feed & Cut key ⇒ p. 49 | I | Zoom key ⇒ p. 21 |
| 4 | File key ⇒ p. 46 | | Image function ⇒ p. 49 |
| 5 | Templt (template) key ⇒ p. 41 | J | Area key ⇒ p. 22 |
| 6 | Format key ⇒ p. 36 | | All function ⇒ p. 23 |
| 7 | Setup key ⇒ p. 57 | K | ↵ (enter) key ⇒ p. 14 & 16 |
| 8 | ▭ / ▭ (frame/shading) key ⇒ p. 32 | | New Block function ⇒ p. 16 |
| 9 | Font key ⇒ p. 24 | L | Cursor keys ⇒ p. 14 |
| O | Size key ⇒ p. 25 | M | Symbol key ⇒ p. 17 |
| A | Width key ⇒ p. 27 | N | Space bar ⇒ p. 15 |
| B | Style key ⇒ p. 28 | O | Code key ⇒ p. 14 |
| C | Italic key ⇒ p. 29 | P | Cancel key ⇒ p. 14 |
| D | ▬ / ▬ (line effects) key ⇒ p. 30 | Q | Shift key ⇒ p. 15 |
| E | Vert (vertical) key ⇒ p. 31 | R | Caps key ⇒ p. 15 |
| F | Back Space key ⇒ p. 21 | S | Alt key ⇒ p. 15 |
| | Clear function ⇒ p. 21 | | |

Getting Started

PRECAUTIONS

- Use only Brother TZ tapes with this machine. Do not use tapes that do not have the  mark.
- Before installing a tape cassette, be sure that the tape is correctly fed under the tape guides.
- Do not pull on the tape being fed from the P-touch. Doing so may damage the tape cassette.
- Avoid using the machine in extremely dusty places. Keep it out of both direct sunlight and rain.
- Do not expose the machine to extremely high temperatures or humidity.
- Do not leave any rubber or vinyl on the machine for an extended period of time. Doing so may cause staining.
- Do not clean the machine with alcohol or other organic solvents. Only use a soft, dry cloth.
- Do not put any foreign objects into or heavy objects on the machine.
- To avoid injuries, do not touch the cutter's edge.
- Use only the power supply cord designed exclusively for this machine. Use of any other cord will void the warranty.
- When the machine is not being used for a long period of time, disconnect the power supply cord.
- A blank horizontal line appearing in a printed label may indicate that there is dust on the print head. Clean the print head by gently wiping up and down along the print head with a dry cotton swab. For more details, see page 71.
- Never try to disassemble the P-touch.

Connecting the power supply cord

This P-touch can be used anywhere a standard electrical outlet is available.

- 1 Insert the plug on the end of the power supply cord into the power supply connector on the back of the P-touch.
- 2 Insert the pronged plug on the other end of the power supply cord into an AC outlet.

NOTE

Only use the power supply cord designed exclusively for this machine.

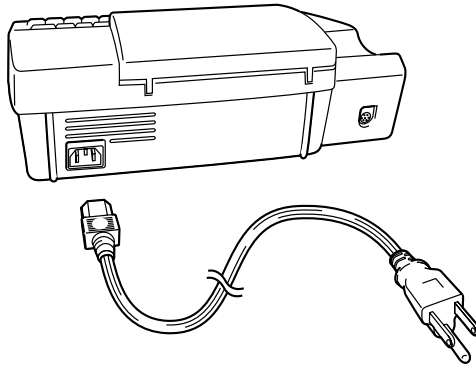

Installing a TZ tape cassette

A TZ tape cassette is supplied with this P-touch. TZ tape cassettes are available for this machine in a wide variety of colors and sizes, making it possible to make distinctive color-coded and stylized labels. In addition, this machine has been designed to allow you to change the tape cassettes quickly and easily.

- 1 Press the cover release button, and then lift open the tape compartment cover.

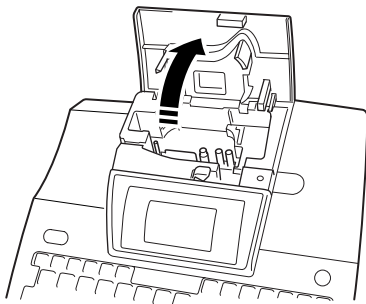

- 2 If a tape cassette is already installed and you wish to replace it, remove it by pulling it straight out.
- 3 If the ink ribbon is loose in the tape cassette to be installed, use your finger to wind the toothed wheel in the direction of the arrow on the cassette until there is no slack in the ribbon. Also, **make sure that the end of the tape feeds under the tape guides.**

- 4 Insert the tape cassette firmly into the compartment, making sure that the entire back of the cassette touches the bottom of the compartment.

NOTE
When inserting the tape cassette, make sure that the ink ribbon does not catch on the corner of the metal guide.

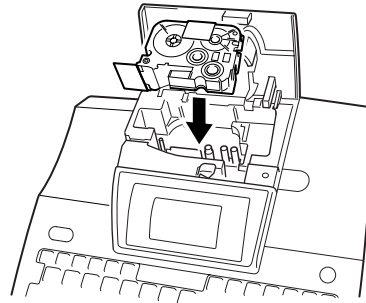

- 5 Close the compartment cover and press the power supply key (⏻) to turn on the machine if it is off. The width of the currently installed tape is shown by the tape width indicator on the right edge of the display.

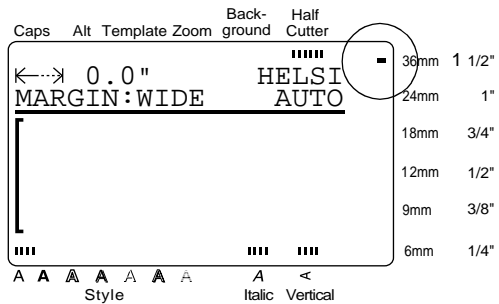

- 6 Press **Feed & Cut** once to remove any slack in the tape and cut off the excess.

Turning on & off the P-touch

.....

The power supply key (⏻) is located in the top right corner of the machine's keyboard. This P-touch will automatically turn off if no key is pressed or no operation is performed for 30 minutes. In addition, if it has remained plugged in, the previous session's text is displayed when you turn it on again.

- Press ⏻ to turn on or turn off the P-touch.

Chapter 3

Functions

Performing basic operations

Although most functions can be used just by pressing their keys, the following keys may be needed with certain functions.

Code ()

To use a function printed in yellow on a key, hold down  while pressing the key for the function that you wish to use.

Enter ()





To select a function from a menu or an item from a list, or to apply the selected setting, press









Cancel ()

To quit a function without applying any changes that you may have made, press .







Cursor keys

The four cursor keys (, , , and ) can be used to perform two operations: to move the cursor, which appears as either a bracket (|) or an underline (_), or to make a selection.





(right)

- To move the cursor one space or character to the right, press  once. If the cursor is at the end of a line when this key is pressed, the cursor moves to the beginning of the next line.
- To move the cursor to the end of the current line of text, hold down  and press .
- To move the cursor to the beginning of the next text block, hold down  and press .
- To select the item on the right in a list, press .





(left)

- To move the cursor one space or character to the left, press  once. If the cursor is at the beginning of a line when this key is pressed, the cursor moves to the end of the previous line.
- To move the cursor to the beginning of the current line of text, hold down  and press .
- To move the cursor to the beginning of the current text block, hold down  and press . If the cursor is already at the beginning of a text block when these keys are pressed, the cursor moves to the beginning of the previous block.
- To select the item on the left in a list, press .

(up)

- To move the cursor to the character in the line directly above the cursor's current position, press  once.
- To move the cursor to the beginning of the entire text, hold down  and press .
- To select the item above in a menu or list, press .

(down)

- To move the cursor to the character in the line directly below the cursor's position, press  once.
- To move the cursor to the end of the entire text, hold down  and press .
- To select the item below in a menu or list, press .

Entering text

Typing in the text for your labels is the same as typing on a typewriter or a computer. In addition, the entered text is normally displayed in WYSIWYG (what-you-see-is-what-you-get) mode, which allows you to see exactly how the label would appear if it were printed.



Space bar ()

To add a blank space to the text, press  (space bar).



Shift ()

To type a capital letter or the symbol printed on the top half of certain keys, like on a typewriter or a computer, hold down  while pressing the key for the character that you wish to type.

Caps ()

To type in series of capital letters without holding down , **Caps** mode must be turned on. **Caps** mode can be turned on or off by pressing . When **Caps** mode is on, the **Caps** indicator lights up.

NOTE

- ☞ When a number key is pressed, the number—not the symbol above it—is typed in, unless  is held down.
- ☞ To type lowercase letters while the **Caps** mode is on, hold down  while pressing the key of the desired character.

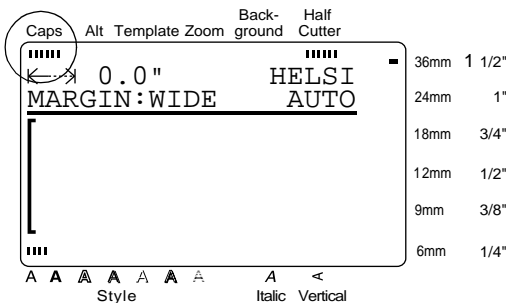

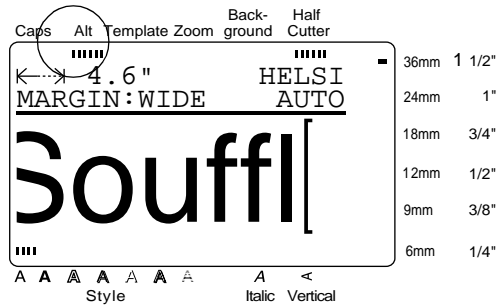

Alt ()

Accented characters or special punctuation marks can be added to the text in **Alt** mode. **Alt** mode can be turned on or off by pressing . When **Alt** mode is on, the **Alt** indicator lights up.



The following table shows the available characters.

Character key	Without  held down, or with Caps mode off	With  held down, or Caps mode on
A	ä á à â ã æ a	Ä Á Â Ã Ä Å Æ A
C	ç c	Ç C
D	ð d	Ð D
E	ë é è ê ë e	É Ê Ë Ì Í Î
I	ï ï ï ï j i	Ï Î Ï
N	ñ n	Ñ N
O	ó ó ó ó õ ø œ o	Ó Ô Õ Ö Ø Æ O
P	p p	þ P
U	ü ú û ü u	Û Ü Û Ü
!	! ? ; : ; " -	! ? ; : ; " -



To add an accented character or a special punctuation mark to the text:



- 1 Press . The **Alt** indicator lights up.

Ch. 3 Functions



2 Press the key for the desired character.

NOTE

☞ To display capital letters, hold down  (or press  to turn on **Caps** mode) before pressing a letter key.

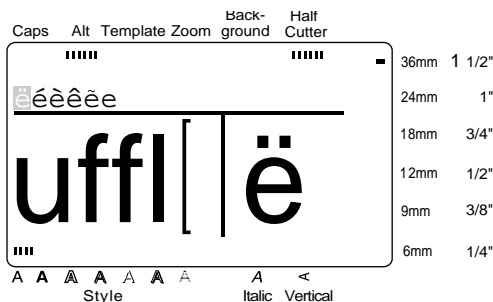
☞ To turn off the **Alt** mode without adding a character to the text, press  (or ) at any time





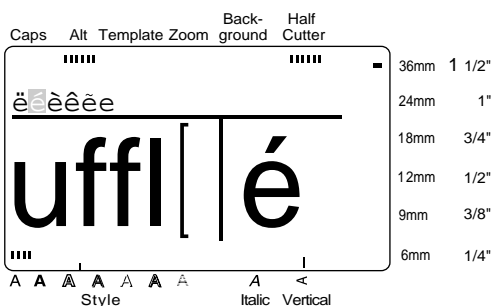

3 Press  or  until the desired accented character or symbol is highlighted.



4 Press . The selected character is added to the text and **Alt** mode turns off.

NOTE

To enter a series of characters in **Alt** mode, hold down  before pressing . Then, continue adding characters by selecting them as explained in steps 2 and 3, and holding down  while pressing . Press just  after selecting the last character in the series.

Enter ()

To create a new line and move the cursor to the beginning of it, press  once you have finished entering a line of text.

NOTE



A single block of text can only contain the maximum number of lines shown in the table below. If the block already contains the maximum number of lines when you press , the error message "LINE LIMIT" will appear.



Tape widths	Maximum number of lines that can be entered
1/4" (6 mm)	2
3/8" (9 mm)	3
1/2" (12 mm)	4
3/4" (18 mm)	6
1" (24 mm)	8
1 1/2" (36 mm)	10

New Block (+)

To change the number of lines in a section of the label, create a new block by holding down  and pressing .

NOTE

☞ A single label can only contain a maximum of five blocks. If five blocks already exist when  is held down and  is pressed, the error message "MAX 5 BLOCKS" will appear.

☞ To split a text block into two so that the character on the right of the cursor is at the beginning of the second block, position the cursor in the middle of the block, and then hold down  and press .

Symbol ()



In addition to the letters, symbols and numerals on the key tops, there are 475 additional symbols and pictures available with the **Symbol** function. After these symbols or pictures are added to the text, they can be deleted like any other character and some can be formatted using certain text format functions (see pages 24 through 31).

A table of the available symbols can be found on pages 76 through 79.

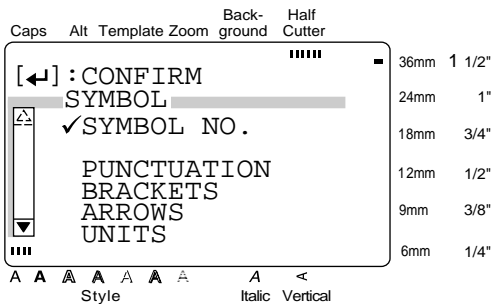

To add a symbol or picture to the text:

- 1 Press .



- 2 Press  or  until **✓** moves beside either **SYMBOL NO.** or the desired category name.



NOTE

- ☞ To return to the previous screen without keeping any changes, press .
- ☞ To return to the text without adding a symbol, press  at any time.

- 3 Press .



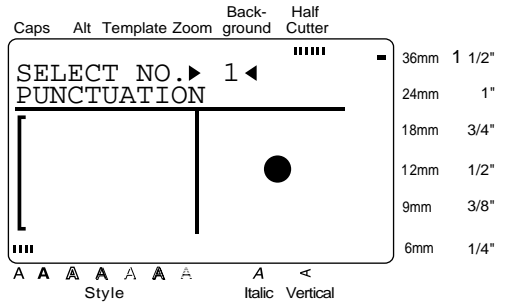

- 4 Select the desired symbol.

If **SYMBOL NO.** was selected:









Type in a symbol number (or press  or ) until the desired symbol is displayed. The name of the category containing the selected symbol is shown in the second line at the top of the display.



If a category was selected:

Press  or  until the desired row of symbols is selected, and then press  or  until the desired symbol is highlighted. An enlargement of the selected symbol is shown on the right half of the display. For the numbers of symbols, refer to the list of symbols in the *Appendix*.

NOTE

- ☞ To select the first symbol in a different category, hold down  and press  or .
- ☞ To select the first symbol, press  (space bar) (or hold down  and press .
- ☞ To select the last symbol, hold down  and press .

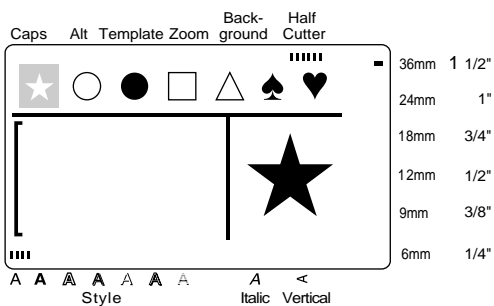

5 Press . The selected symbol is added to the text.

NOTE

- ☞ To enter a series of symbols, hold down before pressing . Then, continue adding characters by selecting them as explained in steps 2 through 4, and holding down while pressing . Press just after selecting the last symbol in the series.
- ☞ Some symbols typed into templates (**Template** function) and backgrounds (**BACKGROUND** function of the **FORMAT** menu) appear on the display as "☒". To view an enlargement of the symbol, move the cursor below it, and then press .

Barcode ()

The **Barcode** function allows you to add your desired barcode to your label. In addition, the various barcode parameters enable you to create custom barcodes.

NOTE

- ☞ This section will explain how to enter a barcode into your text. It is not intended as a comprehensive introduction to the concept of barcoding. For more detailed information, please consult one of the many reference books available.
- ☞ Since this machine is not specifically designed for special barcode label-making, some barcode readers may not be able to read the labels.
- ☞ Barcodes should be printed on white labels with black ink.
- ☞ It is recommended that barcodes be printed with the **MARGIN** function (**FORMAT** menu) set to **WIDE** and the barcode **WIDTH** parameter set to **WIDE**; otherwise, barcodes may be difficult to read.

To create a barcode:

1 Press .

NOTE

- ☞ To change the data or parameters of a barcode that has already been added to the text, position the cursor in the middle of the barcode mark before pressing .
- ☞ To return to the previous screen without keeping any changes, press .
- ☞ To return to the text without adding a barcode, press at any time.

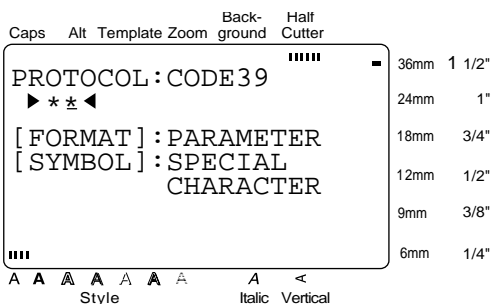

To change the barcode parameters:

2 Press . All or some of the following parameters can be set.

PROTO (protocol)

WIDTH (bar width)

UNDER#S (numbers printed below barcode)

CH.DIG. (check digit)

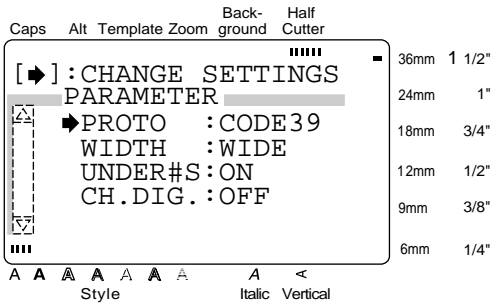

3 Press or until moves beside the parameter that you want to change.

4 Press . The available settings are displayed.

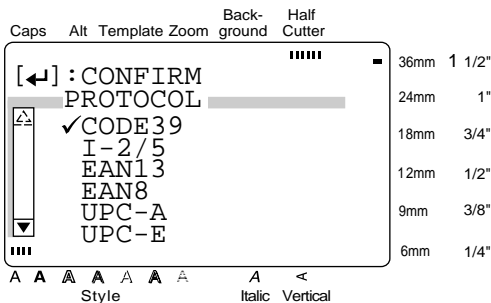

5 Press or until moves beside the desired setting.

NOTE

To select the default setting, press (space bar).

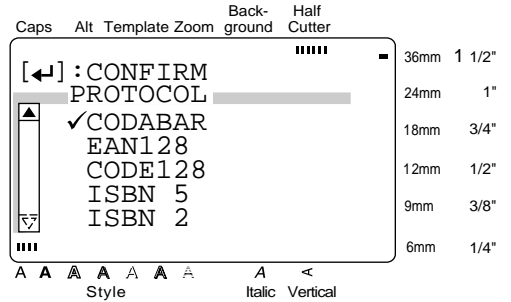

6 Press to confirm the setting and return to the **PARAMETER** menu.

7 Repeat steps 3 through 6 until all parameters are set as you wish.

8 Press to apply the settings.

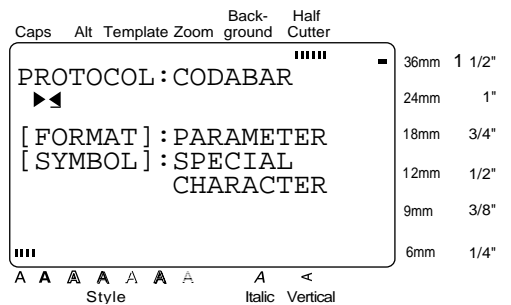

Functions

Ch. 3 Functions

To enter the barcode data:

9 Type in the barcode data.

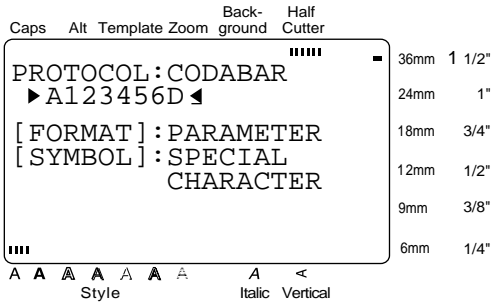

To add special characters to barcodes (only with protocols EAN128, CODE128, CODE39 or CODABAR):

O Press or until the cursor is below the character on the right of where you want to add the special character.

A Press .

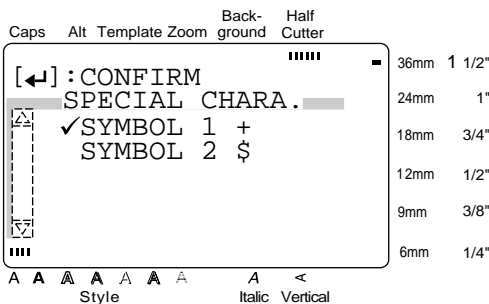

B Press or until ✓ moves beside the special character that you want to add.

NOTE

Refer to page 80 for tables of the special characters that are available.

C Press . The selected special character is added to the barcode data.

To add the barcode to the text:

D Press .

NOTE

To delete a barcode, move the cursor to the center or the right of the barcode and press . When the message "OK TO CLEAR BARCODE?" appears, press or until ✓ moves beside OK, and then press . To return to the text without deleting the barcode, press (or move ✓ beside CANCEL, and then press).

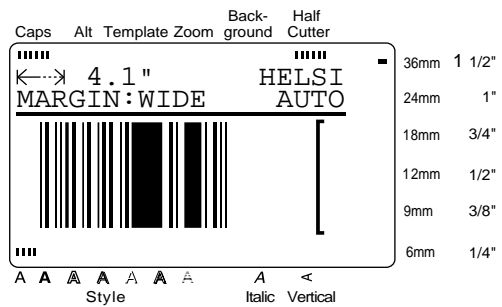



Editing text



Zoom ()

To view text that is too small to be read on the display, the **Zoom** mode must be turned on, making it easier to edit the text. **Zoom** mode can be turned on or off by pressing . When the **Zoom** mode is on, the **Zoom** indicator lights up. In **Zoom** mode, the top, bottom, and left edge of the label are shown by dark lines and the current line number is shown at the bottom of the display.

NOTE

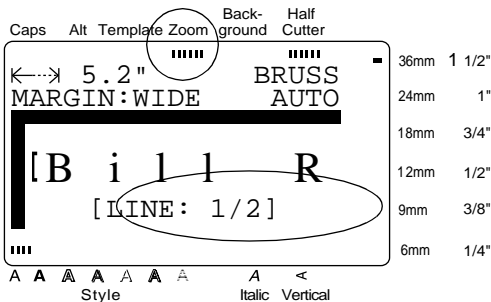
- Use the cursor keys to move around the text.
- To return to WYSIWYG mode, press  (or ).



In addition, pressing  while typing text into templates (**Template** function) and backgrounds (**BACKGROUND** function of the **FORMAT** menu) displays an enlargement of the character above the cursor. This allows you to view symbols which appear on the display as "  ".

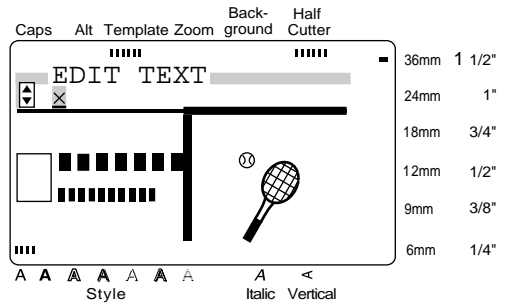

NOTE

To return to editing the text, press any key



Back Space ()

To remove the character in the text that is to the left of the cursor's current position, press .

Each time  is pressed, one character is deleted. If the cursor is at the beginning of a line or a block when  is pressed, the current line or block is joined with the previous one.

Clear (+)

Once you have printed your text, you will need to erase the display so that you can design a new one. With the **Clear** function, you can select whether all of the text and all of the format settings, or just the text and its text format settings will be erased.



NOTE

The cursor can be located anywhere in the text.

To erase all of the text and formats:

- Hold down  and press .

NOTE

To return to the text without erasing anything, press  (or move  beside **CANCEL** and press ).

Ch. 3 Functions

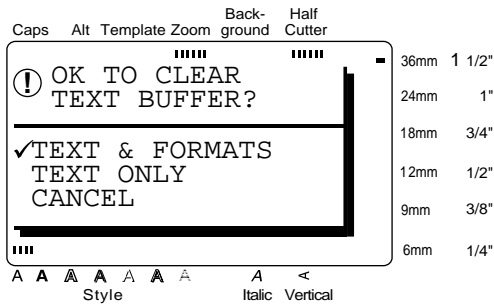



- 2 Since ✓ is already beside **TEXT & FORMATS**, press . All of the text is erased and all of the format functions are reset to their default settings.

To erase only the text:



- 1 Hold down  and press .

NOTE

To return to the text without erasing anything, press

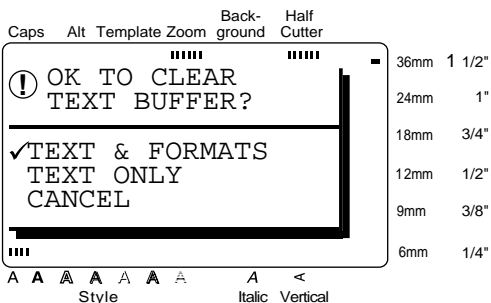
 (or move ✓ beside **CANCEL** and press ).



- 1 Press  or  until ✓ moves beside **TEXT ONLY**.

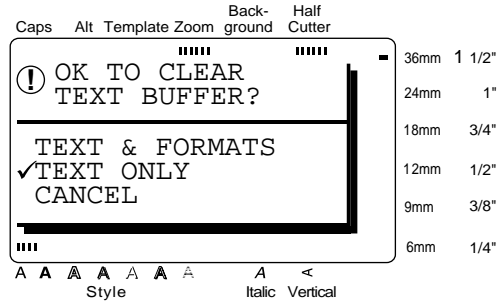

- 2 Press . The text is erased and the text format functions are reset to their default settings, but the label format functions (**FORMAT** menu) remain unchanged.

Area ()

Text formatting with the **Area** function is different from creating a new block using the **New Block** function. With the **Area** function, text within a line or group of lines can be selected so that its text formats can be changed. The selected text can also be deleted or copied and pasted in a different place in the text.

The following two labels show how these functions can be used.

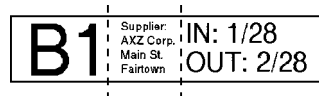

The multiple blocks in this label were created using the **New Block** function. The first block of this text contains a single line, the second contains four lines, and the third, two lines.



This is a single-block, single-line label with different parts of the text formatted using the **Area** function. After all of the text was typed in, section "(123) 456-7890" was selected and given a smaller character size.

To select an area of the text:

- 1 Press , , , or until the cursor is beside the first character that you want to select.

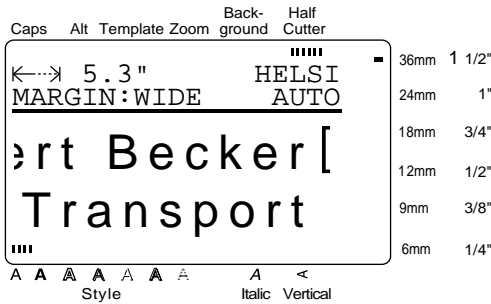

- 2 Press . The first character is highlighted.

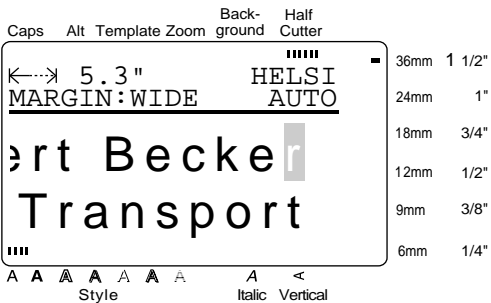

- 3 Press , , , or until all of the characters that you want to select are highlighted.

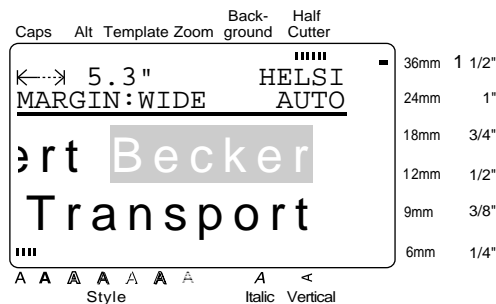

- 4 Format the text using the text format functions (see pages 24 through 31) or use the **Copy & Paste** function to copy the text and paste it into a different place in the text (see page 24).

NOTE

To deselect the text, press (or).

To delete the selected characters, press . When the message "OK TO CLEAR AREA?" appears, press or until moves beside **OK**, and then press . To return to the text without deleting the selected area, press (or move beside **CANCEL**, and then press .

All (+)

With the **All** function, all of the text can be selected so that it can be formatted together, deleted, or copied and pasted in another place in the text.

To select all of the text:

- 1 Hold down and press . All of the text is highlighted.

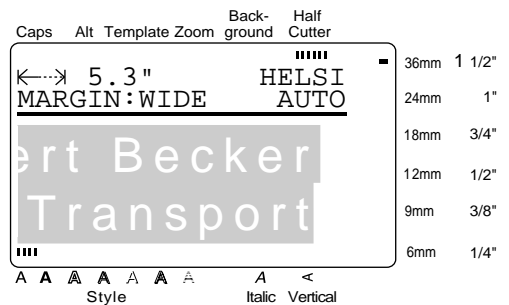

- 2 Format the text using the text format functions (see pages 24 through 31) or use the **Copy & Paste** function to copy the text and paste it into a different place in the text (see page 24).

NOTE







To deselect the text, press .

Ch. 3 Functions



Copy & Paste ()

The **Copy & Paste** function is useful for copying already entered characters and pasting them into a different section of the text.

To copy and paste text:

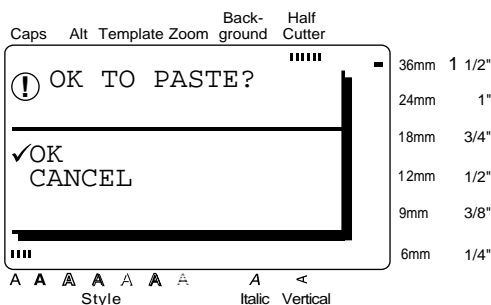
- 1 Select the text that you wish to copy and paste using either the **AREA** function (see page 22) or the **ALL** function (see page 23).
- 2 Press . The selected characters are copied, but not removed from the text.
- 3 Press , , , or  until the cursor is positioned where you want to add the copied text.
- 4 Press .



- 5 Press  or  until ✓ moves beside **OK**.
- 6 Press . The text is added at the cursor's location.

Formatting

A variety of formatting functions are available for making more decorative labels.

The following text formatting functions can be used to change the appearance of characters:

Font, Size, Width, Style, Italic, A / A (line effects) and **Vert** (vertical). They can be applied to part or all of the text, either before or after you have entered it.







The label formats, listed in the **FORMAT** menu, specify the general appearance of the label.

Font ()

With the **Font** function, you can change your text's font to one of the many that are available. Refer to the font samples on page 80. The font of the text at the cursor's current position is shown at the right end of the top line in the top of the display.

NOTE

While selecting a **Font** setting, the following operations may be used:

- ☞ To display the previous setting, hold down  and press .
- ☞ To select the default setting (**HELSINKI**), hold down  and press .
- ☞ To return all text formatting functions to their default settings, hold down  and press  (space bar).
- ☞ To return to the text without making any changes, press .

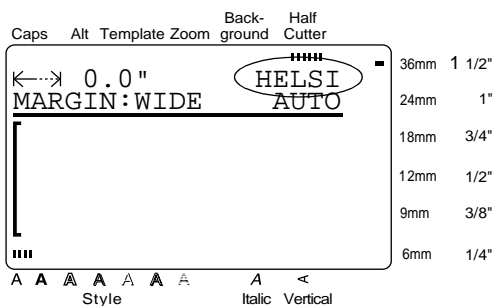

To change the font before entering the text:

- 1 Press , , , or until the cursor is moved to the point where you want to begin using a different font.
- 2 Press until the desired font is selected. The current setting is shown below **FONT** at the top of the display and a sample (**A**) can be seen to the right of the cursor.

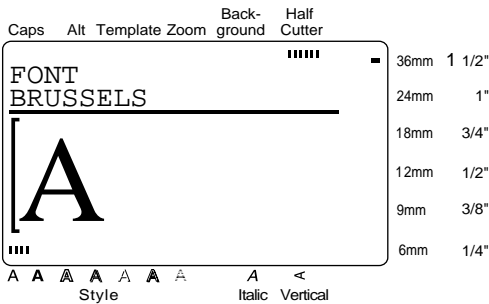

- 3 Type in the new text.

To change the font of the text in a selected area:

- 1 Hold down and press to select all of the text, or press and use , , , or to select only a part of it.
- 2 Press until the text is displayed in the desired font. The current setting is shown below **FONT** at the top of the display.

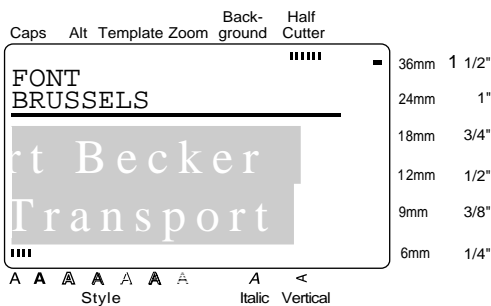

- 3 Press . The selected text is displayed in the desired font.

Size ()

The character size can be adjusted using the **Size** function. With the **AUTO** setting, the machine compares your text with the width of the installed tape and automatically adjusts the characters to the largest possible size. Refer to page 81 for examples of the **Size** settings. The size of the text at the cursor's current position is shown at the right end of the second line in the top of the display.

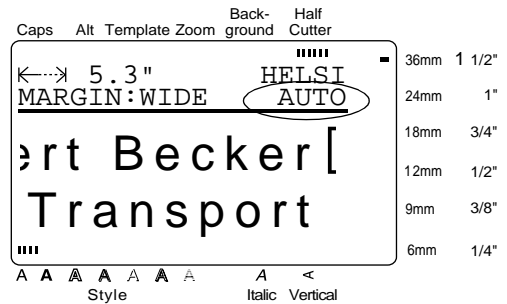

NOTE







- ☞ With the **AUTO** setting selected and 1/2" (12-mm), 3/4" (18-mm), 1" (24-mm) or 1 1/2" (36-mm)-wide tape installed, the size of text with just one line and not containing lowercase letters or certain symbols is printed slightly larger.
- ☞ If a very small text size is selected, the text may not be readable in WYSIWYG mode. When editing such small text, turn on the **Zoom** mode. For more details, refer to page 21.
- ☞ Since the text sizes that can be printed depends on the width of the tape, the following table shows the maximum text size that can be used with each tape width.

Tape widths	Maximum text size (in points)
1/4" (6 mm)	12
3/8" (9 mm)	18
1/2" (12 mm)	24
3/4" (18 mm)	36
1" (24 mm)	60
1 1/2" (36 mm)	72





Ch. 3 Functions

NOTE

While selecting a **Size** setting, the following operations may be used:

- ☞ To display the previous setting, hold down  and press .
- ☞ To select the default setting (**AUTO**), hold down  and press .
- ☞ To return all text formatting functions to their default settings, hold down  and press  (space bar).
- ☞ To return to the text without making any changes, press .





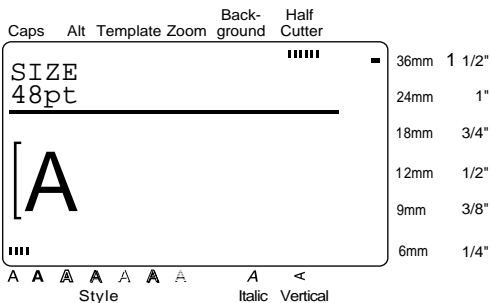



To change the text size before entering the text:

- 1 Press , , , or  until the cursor is moved to the point where you want to begin using a different text size.
- 2 Press  until the desired text size is selected. The current setting is shown below **SIZE** at the top of the display and a sample (**A**) can be seen to the right of the cursor.



- 3 Type in the new text.

To change the size of the text in a selected area:

- 1 Hold down  and press  to select all of the text, or press  and use , , , or  to select only a part of it.
- 2 Press  until the text is displayed in the desired text size. The current setting is shown below **SIZE** at the top of the display.

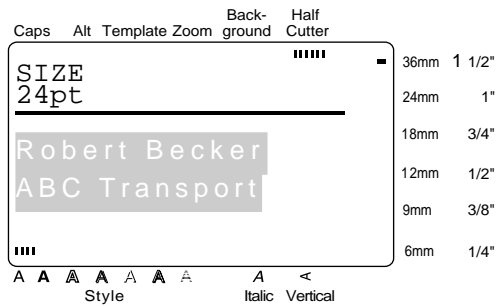

- 3 Press . The selected text is displayed in the desired text size.

Width (Width)

The **Width** function can be used with any of the text sizes to make the size of the characters wider or more narrow. Refer to page 81 for examples of the **Width** settings.

NOTE

While selecting a **Width** setting, the following operations may be used:

- ☞ To display the previous setting, hold down Code and press Width.
- ☞ To select the default setting (**MEDIUM**), hold down Shift and press Width.
- ☞ To return all text formatting functions to their default settings, hold down Code and press (space bar).
- ☞ To return to the text without making any changes, press Cancel.

To change the width before entering the text:

- 1 Press ←, →, ↑, or ↓ until the cursor is moved to the point where you want to begin using a different text width.
- 2 Press Width until the desired width is selected. The current setting is shown below **WIDTH** at the top of the display and a sample (**A**) can be seen to the right of the cursor.

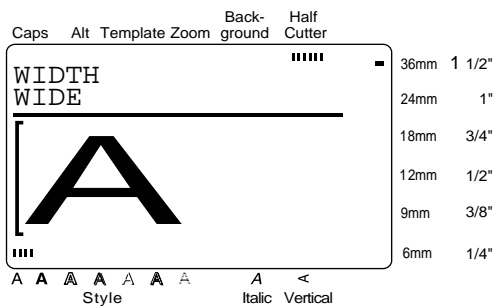

- 3 Type in the new text.

To change the width of the text in a selected area:

- 1 Hold down Code and press Area All to select all of the text, or press Area All and use ←, →, ↑, or ↓ to select only a part of it.
- 2 Press Width until the text is displayed in the desired width. The current setting is shown below **WIDTH** at the top of the display.

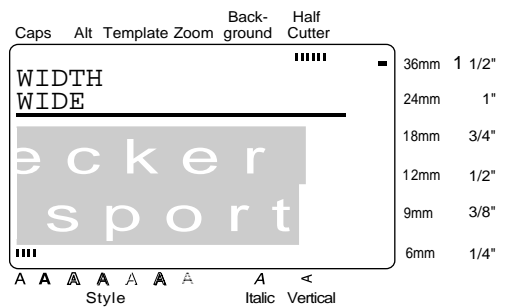

- 3 Press ←. The selected text is displayed in the desired text width.

Ch. 3 Functions

Style (Style)

You can choose from 7 different text styles to create more personalized labels. Refer to the style samples on page 82. The style of the text at the cursor's current position is shown by the **Style** indicators at the bottom of the display.

NOTE

While selecting a **Style** setting, the following operations may be used:

- To display the previous setting, hold down and press .
- To select the default setting (**NORMAL**), hold down and press .
- To return all text formatting functions to their default settings, hold down and press (space bar).
- To return to the text without making any changes, press .

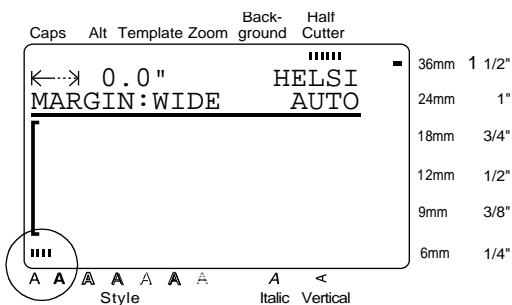

To change the text style before entering the text:

- 1 Press , , , or until the cursor is moved to the point where you want to begin using a different text style.
- 2 Press until the desired style is selected. The current setting is shown below **STYLE** at the top of the display and a sample (**A**) can be seen to the right of the cursor.

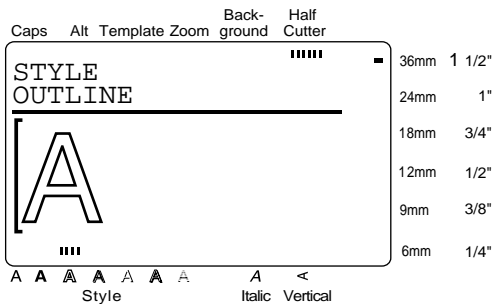

3 Type in the new text.

To change the style of the text in a selected area:

- 1 Hold down and press to select all of the text, or press and use , , , or to select only a part of it.
- 2 Press until the text is displayed in the desired style. The setting is shown below **STYLE** at the top of the display.

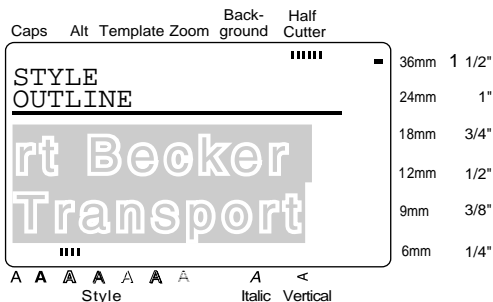





- 3 Press . The selected text is displayed in the desired text style.

Italic ()

The **Italic** function can be combined with each of the other text format settings to provide an even larger variety of text styles. When the **Italic** function is turned on for the text at the cursor's current position, the **Italic** indicator at the bottom of the display lights up.



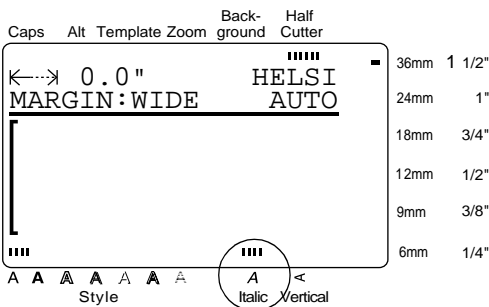

NOTE

While selecting an **Italic** setting, the following operations may be used:

- ☞ To select the default setting (**OFF**), hold down  and press .
- ☞ To return all text formatting functions to their default settings, hold down  and press  (space bar).
- ☞ To return to the text without making any changes, press .







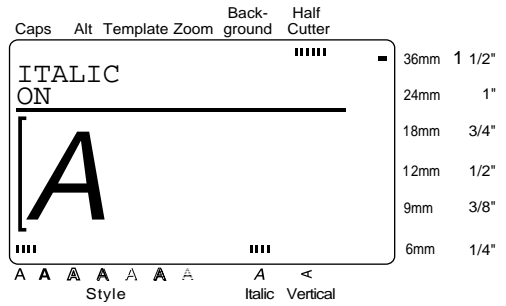



To change the Italic setting before entering the text:

- 1 Press , , , or  until the cursor is moved to the point where you want to begin using a different **Italic** setting.
- 2 Press  to select either **ON** or **OFF**. The current setting is shown below **ITALIC** at the top of the display and a sample (**A**) can be seen to the right of the cursor.



3 Type in the new text.

To change the Italic setting for the text in a selected area:

- 1 Hold down  and press  to select all of the text, or press  and use , , , or  to select only a part of it.
- 2 Press  until the text is displayed with the desired **Italic** setting. The current setting is shown below **ITALIC** at the top of the display.

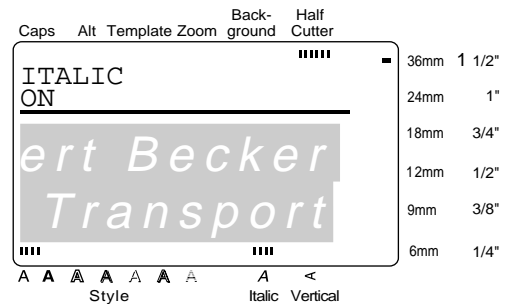

- 3 Press . The selected text is displayed with the desired **Italic** setting.

Ch. 3 Functions

Line effects (A/A)

The **Line effects** function enables you to underline or strike out certain parts of your text.



NOTE

While selecting a **Line effects** setting, the following operations may be used:

- ☞ To display the previous setting, hold down and press .
- ☞ To select the default setting (**OFF**), hold down and press .
- ☞ To return all text formatting functions to their default settings, hold down and press (space bar).
- ☞ To return to the text without making any changes, press .

To change the **Line effects** setting before entering the text:

- 1 Press , , , or until the cursor is moved to the point where you want to begin using a different **Line effects** setting.
- 2 Press until the desired setting is selected. The current setting is shown below **LINE EFFECTS** at the top of the display and a sample (A) can be seen to the right of the cursor.

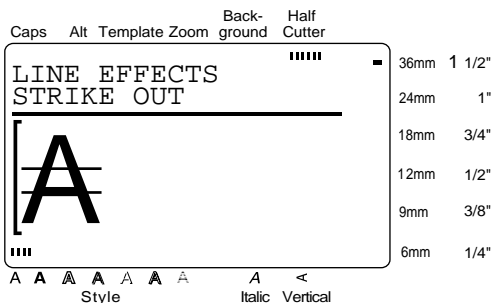

- 3 Type in the new text.

To change the **Line effects** setting for the text in a selected area:

- 1 Hold down and press to select all of the text, or press and use , , , or to select only a part of it.
- 2 Press until the text is displayed with the desired **Line effects** setting. The current setting is shown below **LINE EFFECTS** at the top of the display.

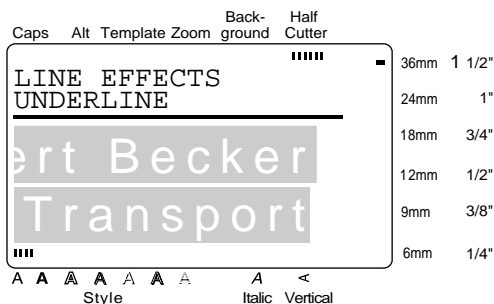

- 3 Press . The selected text is displayed with the desired **Line effects** setting.

Vertical (Vert)

With the **Vertical** function, you can print your text vertically along the length of your label.



When the **Vertical** function is turned on for the text at the cursor's current position, the **Vertical** indicator at the bottom of the display lights up.

NOTE

While selecting a **Vertical** setting, the following operations may be used:

- ☞ To select the default setting (**OFF**), hold down and press .
- ☞ To return all text formatting functions to their default settings, hold down and press (space bar).
- ☞ To return to the text without making any changes, press .

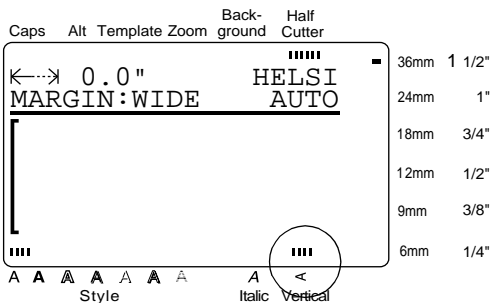

To change the Vertical setting before entering the text:

- 1 Press , , , or until the cursor is moved to the point where you want to begin using a different **Vertical** setting.

- 2 Press to select either **ON** or **OFF**. The current setting is shown below **VERTICAL** at the top of the display and a sample (**A**) can be seen to the right of the cursor.

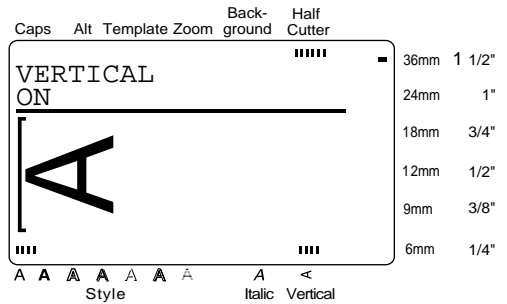

- 3 Type in the new text.

To change the Vertical setting for the text in a selected area:

- 1 Hold down and press to select all of the text, or press and use , , , or to select only a part of the text.
- 2 Press until the text is displayed with the desired **Vertical** setting. The current setting is shown below **VERTICAL** at the top of the display.

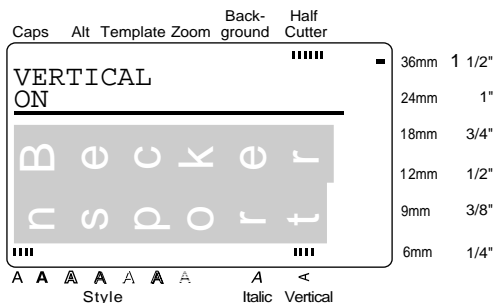

- 3 Press . The selected text is displayed with the desired **Vertical** setting.

Ch. 3 Functions

Frame/shading ()



You can choose from a variety of frames and shadings for emphasizing certain parts or all of the text in your label. Refer to the samples of the frames and shadings on page 83.

To apply a frame or shading to all of the text:



- 1 Press .

NOTE

To return to the text without adding a frame or shading, press  at any time.

- 2 Press  or  until ✓ moves beside the desired setting.

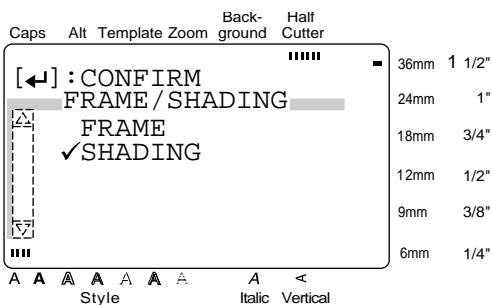

NOTE

- To select the first setting in a menu, press  (space bar).
- To return to the previous screen without keeping any changes, press .

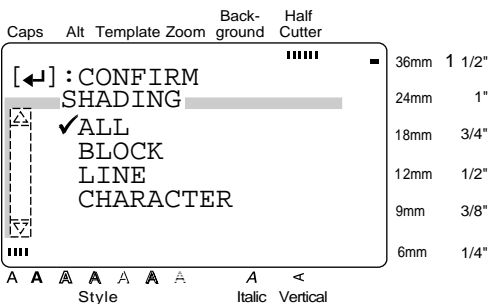

- 3 Press .



- 4 Since ✓ is already beside ALL, press .
- 5 Press  or  until ✓ moves beside the desired frame or shading pattern.

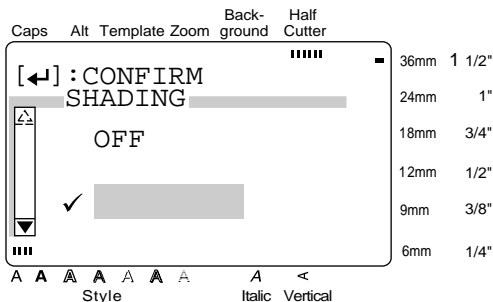



- 6 Press . The desired frame or shading is applied to all of the text.

To apply a frame or shading to selected blocks of text:



- 1 Press .

NOTE

To return to the text without adding a frame or shading, press  at any time.

- 2 Press  or  until ✓ moves beside the desired setting.

NOTE

- To select the first setting in a menu, press  (space bar).
- To return to the previous screen without keeping any changes, press .

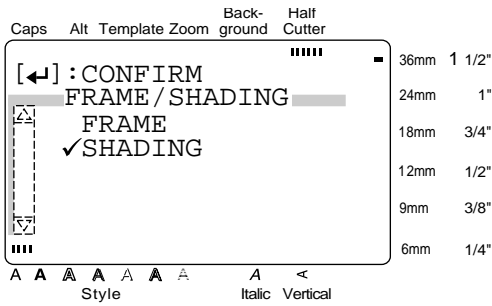

- 3 Press .
- 4 Press or until ✓ moves beside **BLOCK**.

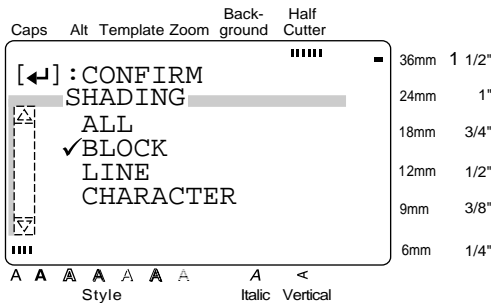

- 5 Press .
- 6 Press or until the first block that you wish to frame or shade is selected.

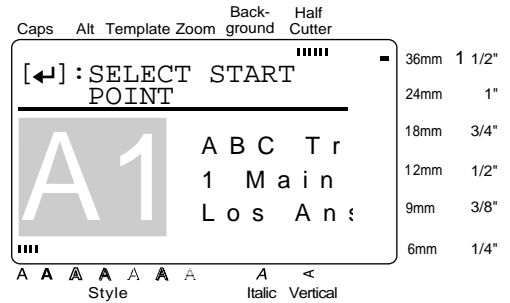

- 7 Press .
- 8 Press or until all of the blocks that you wish to frame or shade are selected.

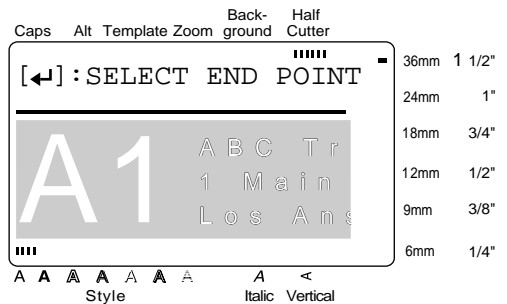

- 9 Press .
- 0 Press or until ✓ moves beside the desired frame or shading pattern.

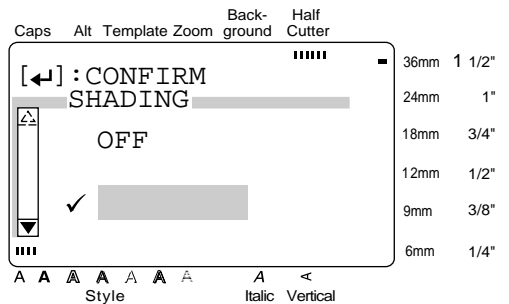

Functions

Ch. 3 Functions

A Press . The desired frame or shading is applied to the selected blocks of text.

NOTE

To delete the frame or shading, position the cursor on the left side of the frame/shading that you wish to delete, and then press . When the message "OK TO CLEAR FRAME/SHADING?" appears, press or until ✓ moves beside **OK** and press . To keep the frame/shading, press (or move ✓ beside **CANCEL**, and then press).

To apply a frame or shading to selected lines of text:

1 Press .

NOTE

To return to the text without adding a frame or shading, press at any time.

2 Press or until ✓ moves beside the desired setting.

NOTE

To select the first setting in a menu, press (space bar).

To return to the previous screen without keeping any changes, press .

3 Press .

4 Press or until ✓ moves beside **LINE**.

5 Press .

6 Press or until the first line that you wish to frame or shade is selected.

7 Press .

8 Press or until all of the lines that you wish to frame or shade are selected.

- 9 Press .
- 0 Press or until ✓ moves beside the desired frame or shading pattern.

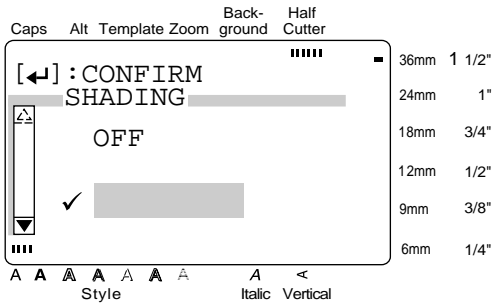

- A Press . The desired frame or shading is applied to the selected lines of text.

To apply a frame or shading to selected characters in the text:

- 1 Press .

NOTE

To return to the text without adding a frame or shading, press at any time.

- 2 Press or until ✓ moves beside the desired setting.

NOTE

- To select the first setting in a menu, press (space bar).
- To return to the previous screen without keeping any changes, press .

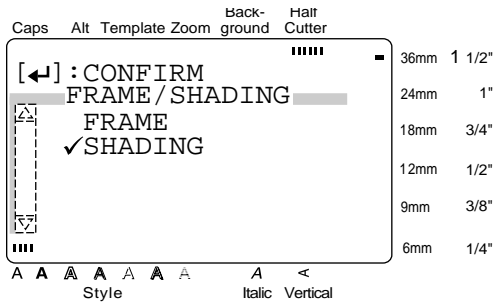

- 3 Press .
- 4 Press or until ✓ moves beside CHARACTER.

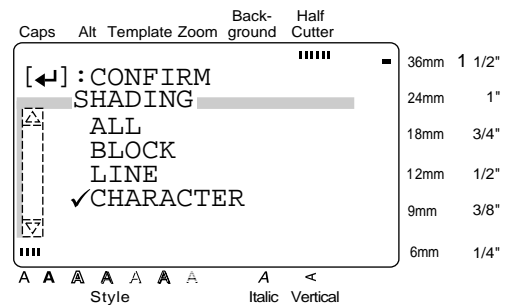

- 5 Press .
- 6 Press , , , or until the first character that you wish to frame or apply a shading to is selected.

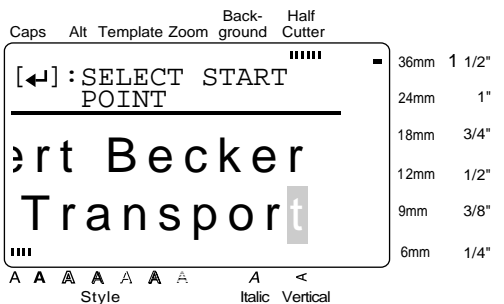

Ch. 3 Functions

- 7 Press .
- 8 Press , , , or until all of the characters that you wish to frame or apply a shading to are selected.

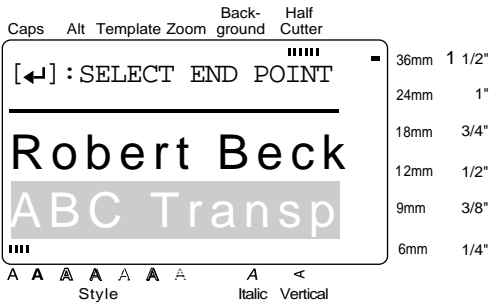

- 9 Press .
- 10 Press or until moves beside the desired frame or shading pattern.

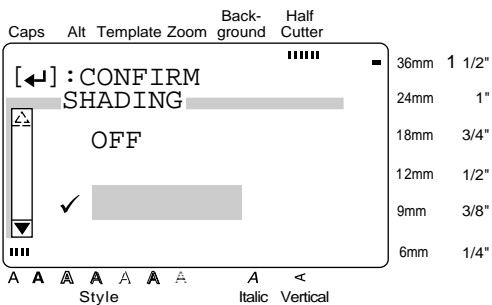

- A Press . The desired frame or shading is applied to the selected characters.

Format ()

Pressing the **Format** key displays a menu containing five label format functions, which can be used to change the label's general appearance.

To change the LENGTH setting:

The currently set label length is shown at the left end of the top line in the top of the display. When the arrow symbol is displayed as "→", the label length is set to **AUTO**. When the arrow symbol is displayed as "→", the label length is set to a certain value.

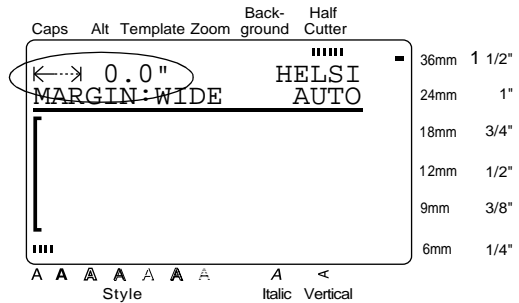

- 1 Press .

NOTE

To return to the text without making any changes, press at any time.

To return all functions in the **FORMAT** menu to their default settings, hold down and press (space bar).

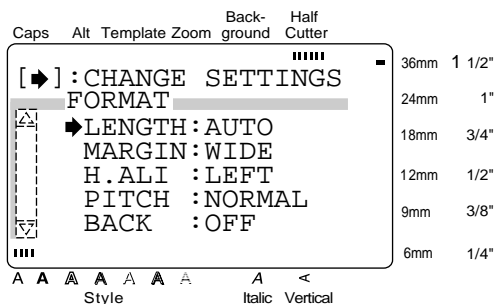

2 Since → is already beside **LENGTH**, press

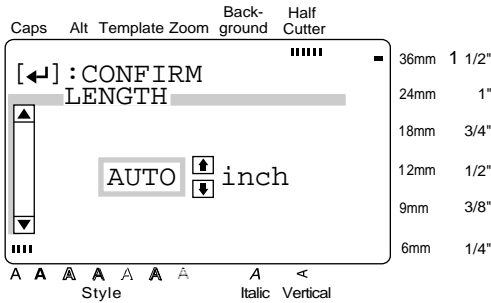

3 Press ↑ or ↓ until the desired setting is displayed (or type in the desired length).

NOTE

- To select the default setting (**AUTO**), press (space bar).
- To return to the previous screen without keeping any changes, press .
- To return to the previous screen with the new setting, press (or).

4 Press once to confirm the setting and return to the **FORMAT** menu.

5 Press again to apply the setting.

To change the MARGIN setting:

This function allows you to select the size of the margins on the left and right sides of your text. When **NONE**, **NARROW** or **MEDIUM** is selected, some extra tape is fed out so that the left and right margins are equal.

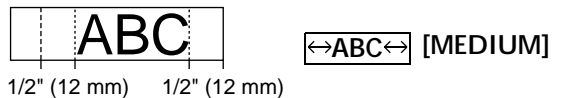
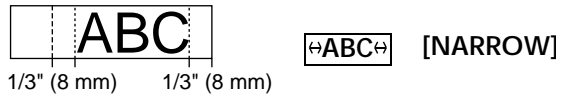
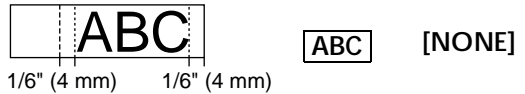
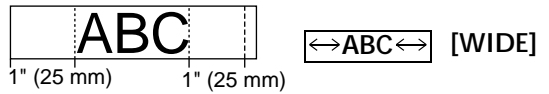

The current margin setting is shown at the left end of the second line in the top of the display.

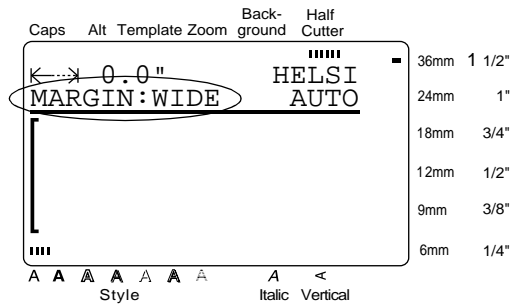

1 Press .

NOTE

- To return to the text without making any changes, press at any time.
- To return all functions in the **FORMAT** menu to their default settings, hold down and press (space bar).

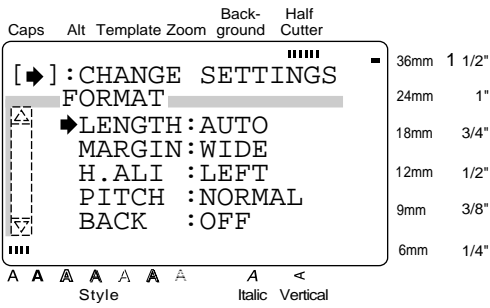

- Press or until moves beside **MARGIN**.
- Press .

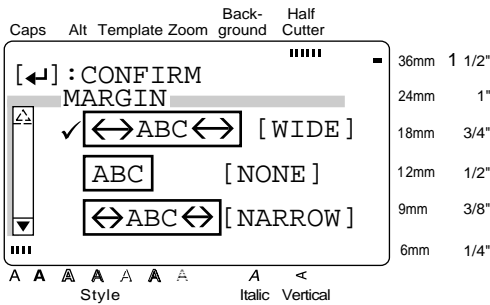

- Press or until moves beside the desired setting.

NOTE

- To select the default setting ([WIDE]), press (space bar).
- To return to the previous screen without keeping any changes, press .
- To return to the previous screen with the new setting, press (or).

- Press once to confirm the setting and return to the **FORMAT** menu.
- Press again to apply the setting.

To change the H.ALI (horizontal alignment) setting:

You can choose to align the text in your label in one of four ways:

ABC
DEFGH IJKLM ←-ABC [LEFT]

ABC
DEFGH IJKLM ←-ABC→ [CENTER]

ABC
DEFGH IJKLM ABC→ [RIGHT]

A B C
DEFGH IJKLM ←-ABC→ [JUSTIFY]

- Press .

NOTE

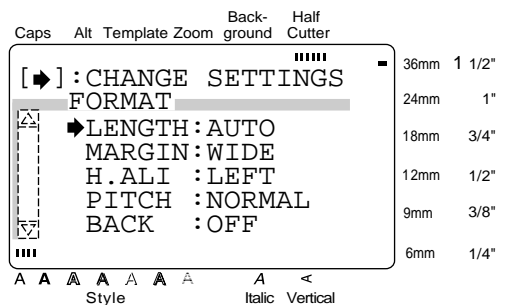

- To return to the text without making any changes, press at any time.
- To return all functions in the **FORMAT** menu to their default settings, hold down and press (space bar).





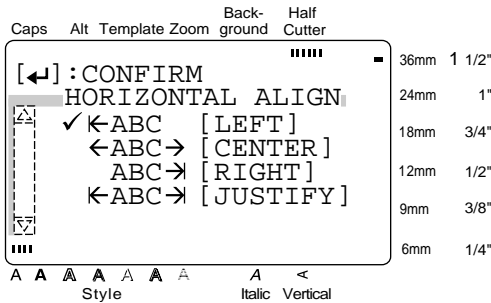

- Press or until moves beside **H.ALI**.

3 Press .



4 Press  or  until ✓ moves beside the desired setting.

NOTE

- To select the default setting (←ABC [LEFT]), press  (space bar).
- To return to the previous screen without keeping any changes, press .
- To return to the previous screen with the new setting, press  (or ).

5 Press  once to confirm the setting and return to the **FORMAT** menu.

6 Press  again to apply the setting.

To change the PITCH setting:

With this function, you can select whether or not each character is given an equal width.

Scanner \$300
Printer \$600
Fax \$399



HIHIHI
[NORMAL]

Scanner \$ 3 0 0
Printer \$ 6 0 0
Fax \$ 3 9 9



HIHIHI
[FIXED]

1 Press .

NOTE

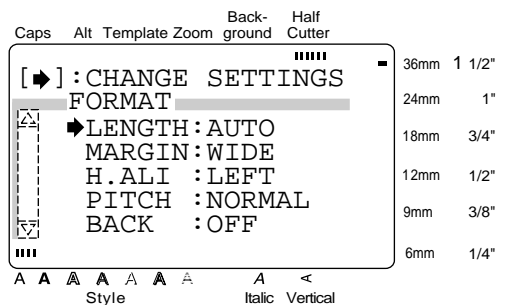
- To return to the text without making any changes, press  at any time.
- To return all functions in the **FORMAT** menu to their default settings, hold down  and press  (space bar).





2 Press  or  until → moves beside **PITCH**.



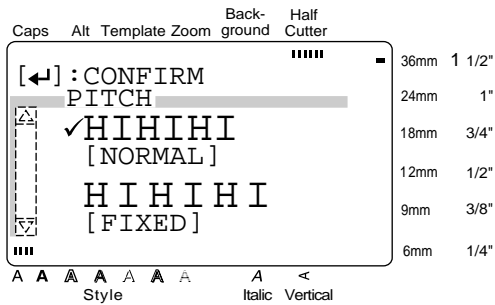



Ch. 3 Functions

3 Press .



4 Press  or  until  moves beside the desired setting.

NOTE

-  To select the default setting (**HIHIHI [NORMAL]**), press (space bar).
-  To return to the previous screen without keeping any changes, press .
-  To return to the previous screen with the new setting, press  (or ).

5 Press  once to confirm the setting and return to the **FORMAT** menu.





6 Press  again to apply the setting.

To change the BACK (background) setting:



From the many designs available, choose a background for your label. You can even create your own backgrounds using text or symbols.

1 Press .

NOTE

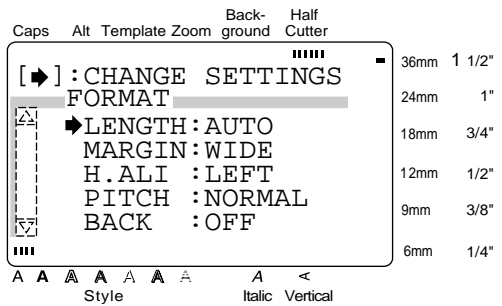

-  To return to the text without making any changes, press  at any time.
-  To return all functions in the **FORMAT** menu to their default settings, hold down  and press (space bar).





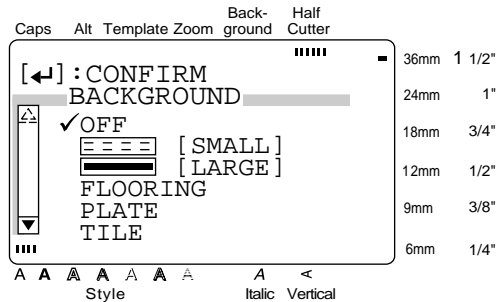



2 Press  or  until  moves beside **BACK**.

3 Press .



4 Press  or  until  moves beside the desired setting.

NOTE

-  To select the default setting (**OFF**), press (space bar).
-  To return to the previous screen without keeping any changes, press .
-  To return to the previous screen with the new setting, press  (or .

- Press once to confirm the setting. If **SMALL** or **LARGE** was selected, type in the desired text, change the font by press until the desired font setting is displayed, and then press . The **FORMAT** menu appears again.

NOTE

- Up to 20 characters can be entered. Symbols (see pages 17 and 18) and accented characters (see page 15) can also be added.
- To display an enlarged view of the character or symbol above the cursor, press . Press any key to continue editing the text.
- To return to the previous screen without keeping any changes, press .

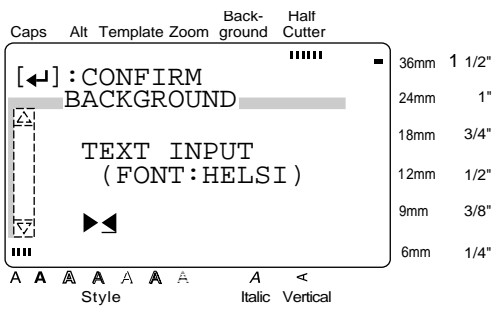

If a pre-made background design was selected, the **FORMAT** menu appears again.

- Press again to apply the setting. The **Background** indicator lights up.

Template ()

The **Template** function makes creating a label or stamp quick and easy. After selecting one of the various pre-formatted templates, simply change the text, and then it is ready to be printed. The many templates available are useful for common needs—from addressing envelopes to identifying floppy disks or audio and video cassettes. The tape width and length of each label printed from a template is preset. Refer to the samples of the available templates on pages 85 to 88.

After the text is entered, the style of the text can easily be changed just by selecting one of the 7 available style formats. Refer to page 89 for samples of the style formats.

To create a label or stamp from a template:

- Press . The **Template** indicator lights up.

NOTE

- If there was text in the display when the **Template** function was started, the message "OK TO CLEAR TEXT BUFFER?" appears.
 - To delete the text, press or until moves beside **OK**, and then press .
 - To return to the text without deleting it, press (or move beside **CANCEL**, and then press .
- To return to the previous screen, press .

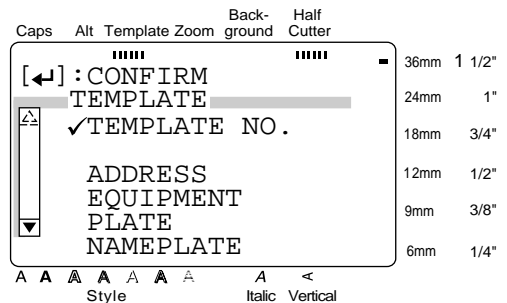

Ch. 3 Functions

2 Select the desired template.

NOTE

☞ To select the first template, press (space bar) (or hold down and press).

☞ To select the last template, hold down and press .

If **TEMPLATE NO.** was selected:

Type in a template number (or press or) until the desired template is displayed. The name of the selected template is shown in the second line at the top of the display.

If a category was selected:

Press or until the desired template is displayed. The number and name of the current template are displayed at the top of the display and the dimensions are shown below it.

3 Press . The first line of the template's text is shown below **EDIT TEXT** at the top of the display. For template numbers and samples, refer to the list of templates in the *Appendix*.

4 Type in the new text.

NOTE

☞ Symbols can also be added. Refer to pages 17 and 18 for details.

☞ To display an enlarged view of the character or symbol above the cursor, press . Press any key to return to editing the text.









☞ To move the cursor through the line of text, press or . To display a different line of text, press or .

☞ To quit using the current template and return to step 2, press . When the message "OK TO CONTINUE TEMPLATE?" appears, press (or move ✓ beside **CANCEL**, and then press). To continue using the current template, press or until ✓ moves beside **OK**, and then press .

5 Press to display the next line of text in the template.



- 6 Repeat steps 4 and 5 until all of the text that you wish to use is entered. The **MENU** appears after the last line of text in the template is edited and  is pressed.

NOTE

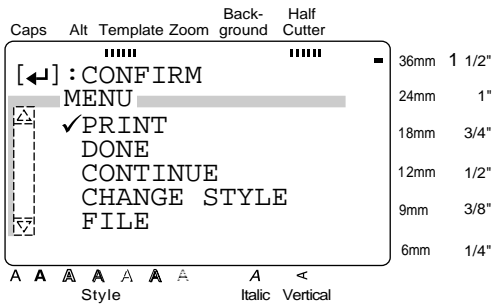
To quit *Template mode*, press  or  until ✓ moves beside **DONE**, and then press . When the message "OK TO FINISH TEMPLATE?" appears, press  or  until ✓ moves beside **OK** and press . To return to *Template mode*, press  (or move ✓ beside **CANCEL**, and then press ).





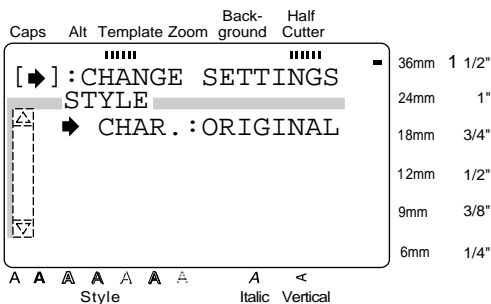

To change the style of a label or stamp created from a template:

- 7 Press  or  until ✓ moves beside **CHANGE STYLE**.
- 8 Press . The current style setting is displayed.

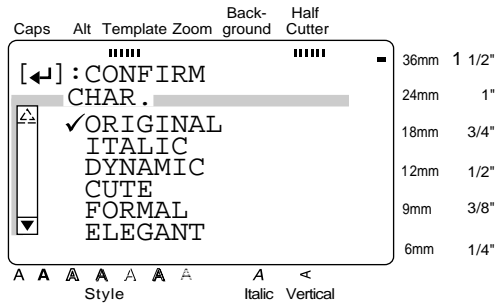



- 9 Press .



- Press  or  until ✓ moves beside the desired setting. Refer to page 89 for samples of these settings.
- A Press  once to confirm the setting and return to the **STYLE** menu.
- B Press  again to apply the setting.

To continue editing the label or stamp:

- C Press  or  until ✓ moves beside **CONTINUE**.
- D Repeat steps 4 and 5 until the text is edited as you wish. The **MENU** appears again after the last line of text in the template is edited and  is pressed.

Functions

Ch. 3 Functions

To print a label or stamp created using a template:

E Press or until ✓ moves beside **PRINT**.

F Press .

NOTE

Be sure that the correct tape cassette is installed.

- When printing a stamp, install a stamp film cassette.
- When printing a label, install a label tape cassette.

If a template other than one from the **STAMP** category was used, the following display appears.

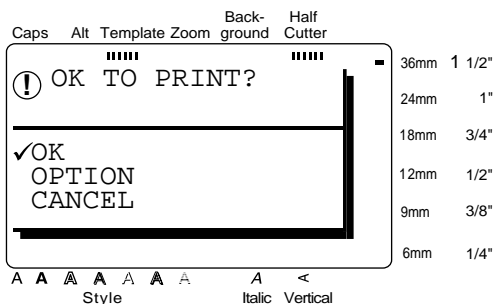

If a template from the **STAMP** category was used, the following display appears.

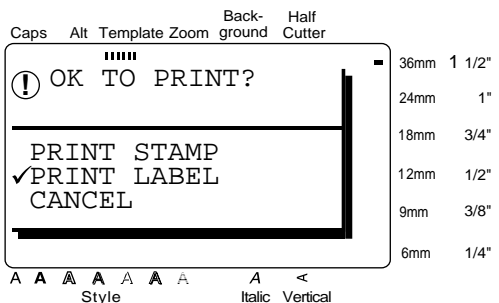

G Press or until ✓ moves beside the desired setting.

For a label created using a template other than one from the **STAMP** category:

To print, select **OK**. Refer to page 49 for more details on printing.

To change the printing options, select **OPTION**. Refer to pages 49 through 54 for more details on the printing options.

For a stamp created using a template from the **STAMP** category:

To print out a stamp stencil, select **PRINT STAMP**.

To print an identification label, select **PRINT LABEL**.

NOTE

Use 1/2" (12-mm)-wide tape to make an identification label for a stamp with a STAMP M size and use 3/4" (18-mm)-wide tape to make a label for a stamp with a STAMP L size.



H Press .

To store the label or stamp created using a template:

I Press or until ✓ moves beside **FILE**.

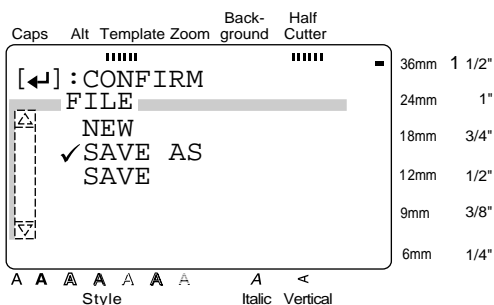
J Press .



K Press  or  until ✓ moves beside the desired setting, and then press  .

Refer to pages 46 and 46 for more details on saving files.

If the file has not been saved before, select **SAVE AS**.

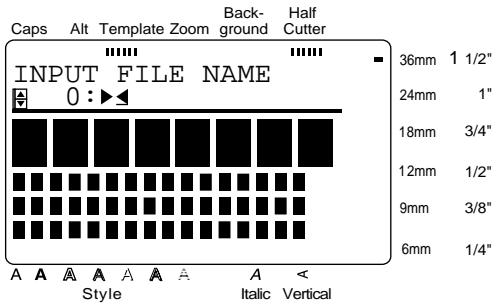

If the file has been saved before, select **SAVE**.

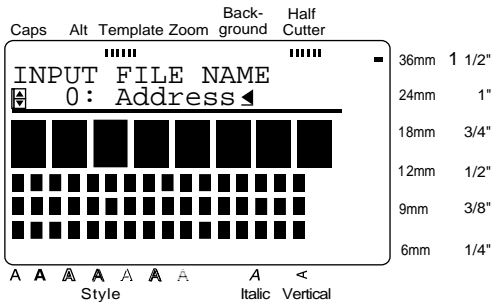



L Type in the desired file name.

NOTE

A file name can only be up to 10 characters long.



M Press  . The text is saved under the selected number with the entered file name.

To create another label or stamp using a different template:

N Press  or  until ✓ moves beside **FILE**.

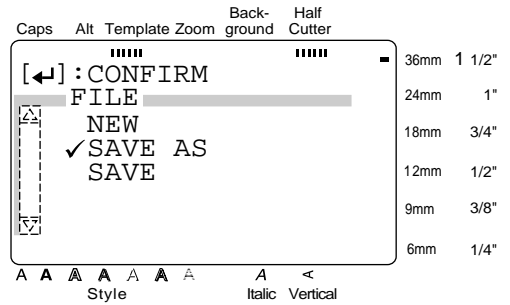

O Press  .

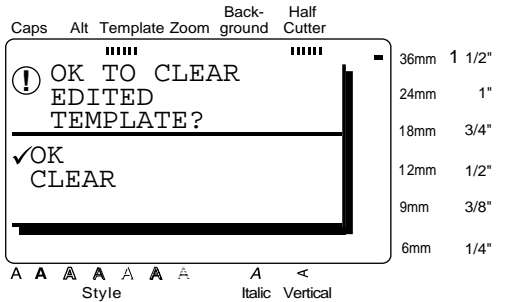

P Press  or  until ✓ moves beside **NEW**.

Q Press  .



R Press  or  until ✓ moves beside **OK**.

NOTE

To return to the **FILE** menu without erasing the edited template, press  (or move ✓ beside

CANCEL, and then press ).

S Press  .

Storing and recalling files

You can store frequently used text in the memory. These text files remain in the memory, even after all characters are erased from the display with the **Clear** function (see page 21).

When each file is stored, it can be given an file name so that it can be searched for. Up to 100 files or about 3,000 characters can be stored in the memory.

Since a copy of the stored text file is recalled when using the **OPEN** function, the text can be edited or printed without changing the originally stored file. However, the **SAVE** function can be used to replace the previously saved file with the new edited one. When a file is no longer needed or more space is necessary, the **DELETE** function can be used to delete it.

To save a file that has not been saved before:

- 1 Press .

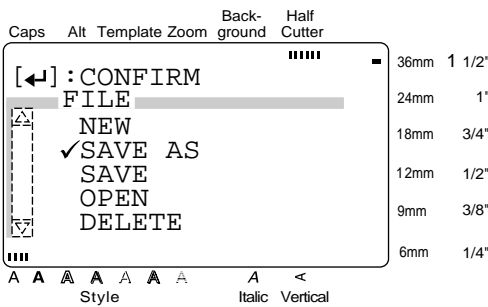



- 2 Since ✓ is already beside **SAVE AS**, press

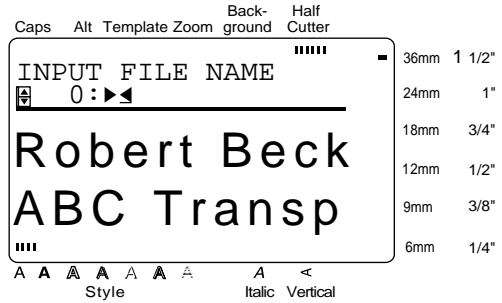

NOTE

To return to the previous screen without making any changes, press .



- 3 Press  or  until the file number where you want to store the text is displayed.

NOTE
File numbers that are not displayed already contain a text file.

- 4 Type in the desired file name.



NOTE
A file name can only be up to 10 characters long.

- 5 Press . The text is saved under the selected number with the entered file name.

To save a file that has been saved before:

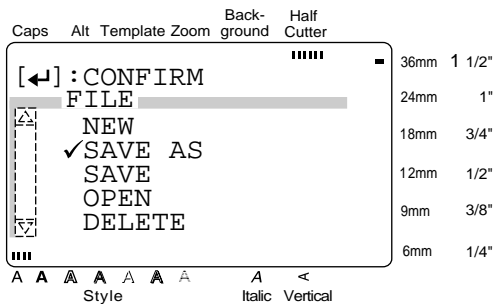
- 1 Press .



- 2 Press  or  until ✓ moves beside **SAVE**.

NOTE

To return to the previous screen without making any changes, press .

3 Press .

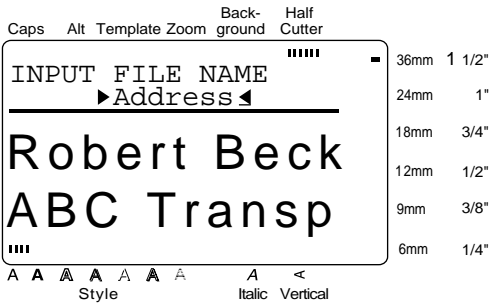

4 Edit the file name if you wish.

NOTE



A file name can only be up to 10 characters long.

5 Press . The text is saved under the selected number with the entered file name.

To recall a file that has been saved:

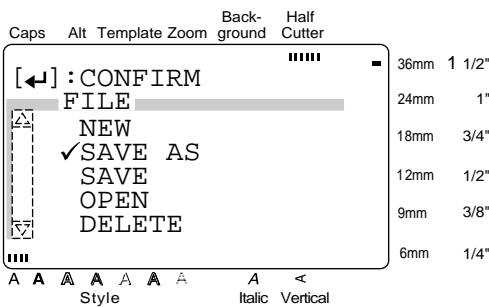
1 Press .



2 Press  or  until  moves beside **OPEN**.







NOTE

To return to the previous screen without making any changes, press .

3 Press .



NOTE

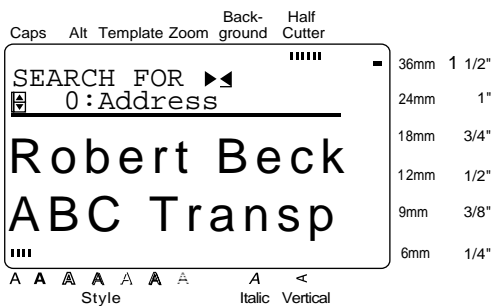

If there was text in the display before the **File** function was started, the message "OK TO CLEAR TEXT BUFFER?" appears.

- To delete the text, press  or  until  moves beside **OK**, and then press .
- To return to the **FILE** menu without deleting the text in the display, press  (or move  beside **CANCEL**, and then press .



4 Select the file that you want to open.

To scan through the saved files, press  or .

To search for a specific file, type in a part of the name of the desired file, and then press . The files with names containing the text that you searched for are found and the first file is displayed. If more than one file is found, press  or  until the file that you want to open is displayed.

Ch. 3 Functions

- Press . The selected file appears in the display.

NOTE

When a file created using a template is opened, it is opened in **Template** mode.

To delete a file that has been saved:

- Press .

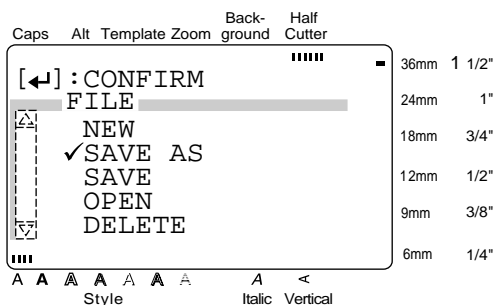

- Press or until moves beside **DELETE**.

NOTE

To return to the previous screen without making any changes, press .

- Press .

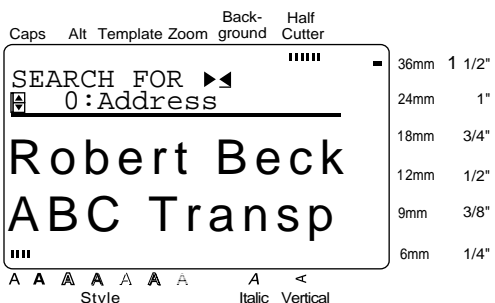

- Select the file that you want to delete.

To scan through the saved files, press or .

NOTE

To select all of the stored files, hold down and press .

To search for a specific file, type in a part of the name of the desired file, and then press . The files with names containing the text that you searched for are found and the first file is displayed. If more than one file is found, press or until the file that you want to delete is displayed, or hold down and press to select all of the found files.

- Press .

NOTE

- If all of the stored files were selected, the message "OK TO CLEAR ALL FILES?" appears.
- If all of the files found by searching were selected, the message "OK TO CLEAR ALL SEARCHED FILES?" appears.

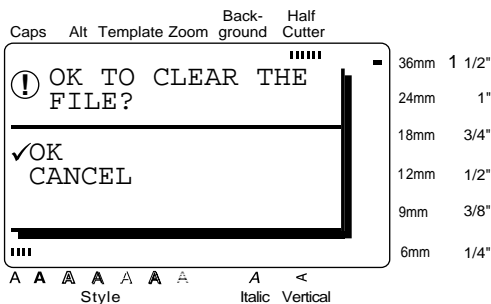

- Press or until moves beside **OK**.

NOTE

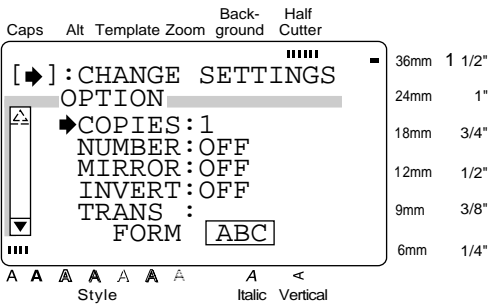

To return to the previous screen without deleting the file, press (or move beside **CANCEL**, and then press).

- Press . The selected file is deleted.



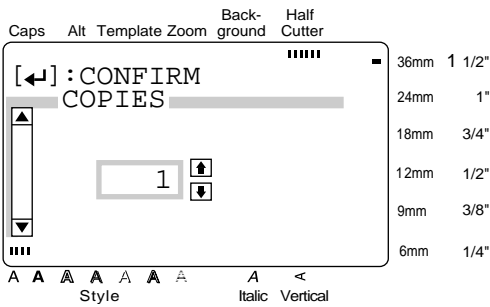

4 Since → is already beside **COPIES**, press



5 Type in a number (or press  or ) until the desired number of copies is displayed.

NOTE

To select the default setting (1), press  (space bar).

6 Press  to confirm the setting and return to the **OPTION** menu.

To change the NUMBER setting:

The **NUMBER** (numbering) function can be used to print many copies of the same text while increasing certain characters (letters, number or barcode data) after each label is printed. This type of automatic incrementation is very useful when printing serial number labels, production control labels or other labels requiring ascending codes.



Letters and numbers increase as shown below:

0 → 1 → ...9 → 0 → ...
 A → B → ...Z → A → ...
 a → b → ...z → a → ...
 A0 → A1 → ...A9 → B0 → ...

Spaces (shown as underlines “_” in the examples below) can be used to adjust the space between characters or to control the number of digits that are printed:

1_9 → 2_0 → ...9_9 → _0 → ...
 _9 → 10 → ...99 → _0 → ...
 _Z → AA → ...ZZ → _A → ...

NOTE

-  Only one numbering field can be selected from any text.
-  If you include a non-alphanumeric character such as a symbol in the numbering field, only the letters and numbers in the numbering field will be increased when the labels are printed, or just one label will be printed if the field only contains a non-alphanumeric character.

1 Press .

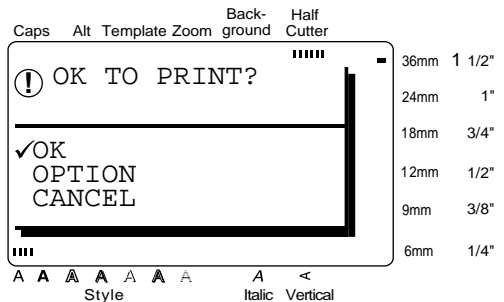

2 Press or to move ✓ beside **OPTION**.

NOTE
To return to the text without making any changes, press at any time.

3 Press .

NOTE

- To display the **OPTION** menu quickly, hold down and press .
- To return to the previous screen without keeping any changes, press .
- To return all functions in the **OPTION** menu to their default settings, hold down and press (space bar).

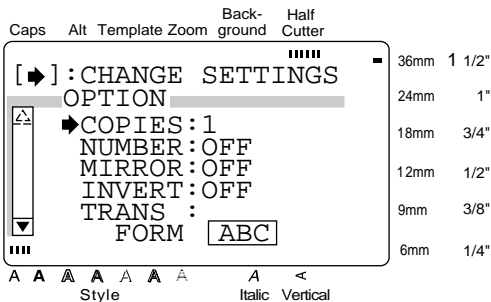

4 Press or to move ➔ beside **NUMBER**.

5 Press .

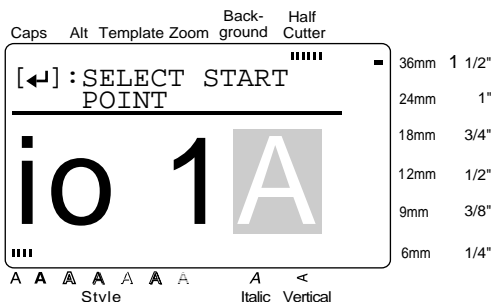

6 Press , , , or until the first character that you wish to select for the numbering field is selected.

7 Press .

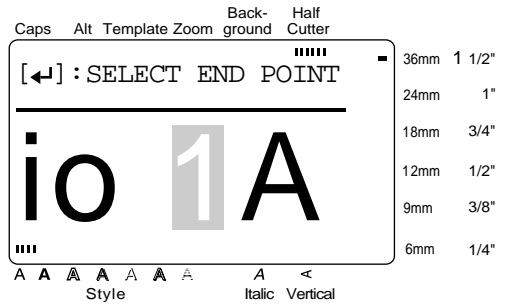

8 Press or until all of the characters that you wish to select for the numbering field are selected.



NOTE

- If a barcode was selected in step 6, this step is skipped.
- A numbering field must be located entirely within one line of text of a single block.
- The maximum number of characters in a numbering field is five.
- If you try to choose more than five characters, the error message "INCORRECT OPERATION FOR NUMBERING FUNCTION" will appear.

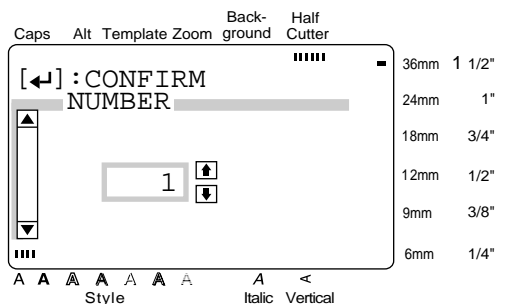
9 Press .



Ch. 3 Functions

A Type in a number (or press  or ) until the desired number of copies is displayed.

NOTE

To select the default setting (**OFF**), press  (space bar).

B Press  to confirm the setting and return to the **OPTION** menu.

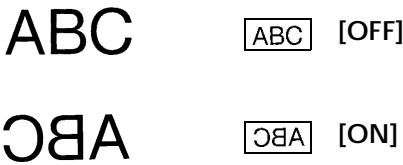

To print a mirror image of the text:

With the **MIRROR** function, you can print your text in reverse so that it can be read from the adhesive side of the tape.



If these labels are printed on clear tape and affixed to glass or any other clear material, the text can be read correctly from the opposite side.

1 Press .



2 Press  or  to move  beside **OPTION**.



NOTE



To return to the text without making any changes, press  at any time.



3 Press .

NOTE



 To display the **OPTION** menu quickly, hold down  and press .

 To return to the previous screen without keeping any changes, press .

 To return all functions in the **OPTION** menu to their default settings, hold down  and press  (space bar).

4 Press  or  to move  beside **MIRROR**.

5 Press .

6 Press  or  to move ✓ beside the desired setting.

NOTE
To select the default setting (**ABC** [OFF]), press  (space bar).

7 Press  to confirm the setting and return to the **OPTION** menu.

To print an inverted image of the text:

The **INVERT** function prints all light areas so that they are dark and all dark areas so that they are light.



NOTE
Some fine details in the printing may be lost when this function is used.

ABC **ABC** [OFF]

ABC **ABC** [ON]

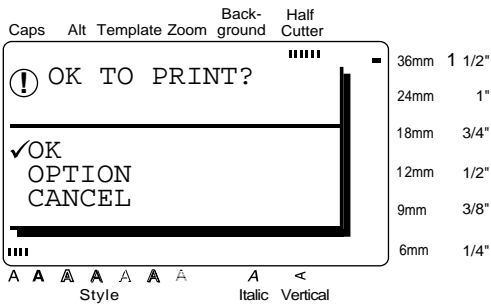

1 Press .





2 Press  or  to move ✓ beside **OPTION**.

NOTE
To return to the text without making any changes, press  at any time.



3 Press .

NOTE
To display the **OPTION** menu quickly, hold down  and press .

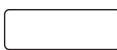
To return to the previous screen without keeping any changes, press .

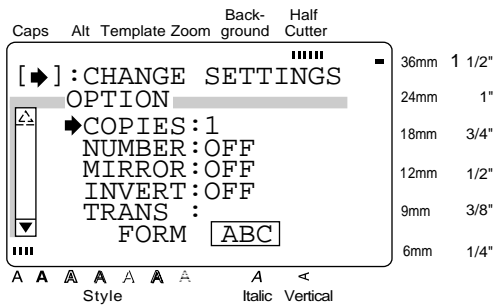

To return all functions in the **OPTION** menu to their default settings, hold down  and press  (space bar).

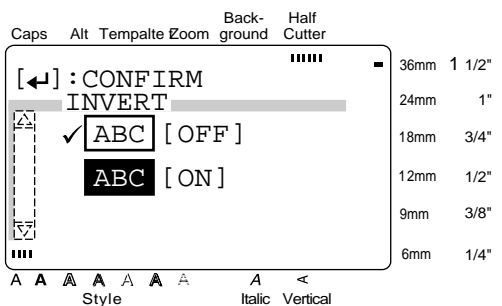

4 Press  or  to move ➔ beside **INVERT**.

5 Press .



6 Press  or  to move ✓ beside the desired setting.

NOTE
To select the default setting (**ABC** [OFF]), press  (space bar).

Ch. 3 Functions



7 Press  to confirm the setting and return to the **OPTION** menu.

To change the shape of the text:

Use the **TRANSFORMATION** function to create interesting text effects by molding the text into different shapes. Refer to page 54 for samples of the shapes that are available.

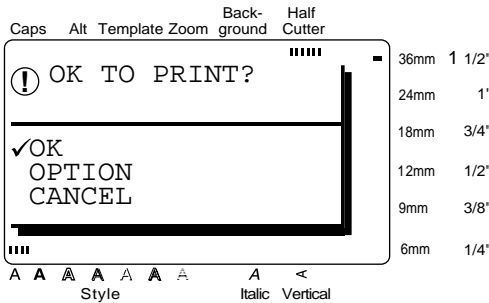
1 Press .





2 Press  or  to move ✓ beside **OPTION**.



NOTE



To return to the text without making any changes, press  at any time.

3 Press .



NOTE

 To display the **OPTION** menu quickly, hold down  and press .

 To return to the previous screen without keeping any changes, press .

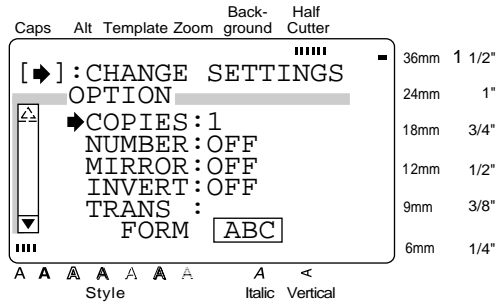

 To return all functions in the **OPTION** menu to their default settings, hold down  and press  (space bar).

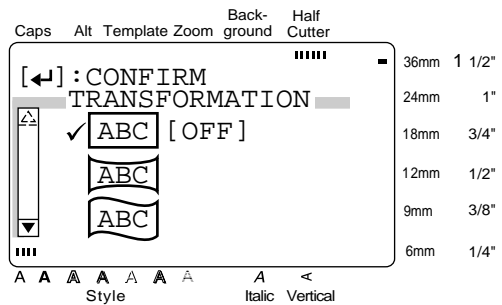

4 Press  or  to move  beside **TRANSFORM**.

5 Press .



6 Press  or  to move ✓ beside the desired setting.

NOTE

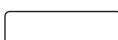
To select the default setting ( [OFF]), press  (space bar).

7 Press  to confirm the setting and return to the **OPTION** menu.

To change the CUT setting:

The way that labels are cut off after being printed can be selected using the **CUT** function. A full cut completely cuts off the label. When a half cut setting is selected, the **HALF CUTTER** indicator lights up and the tape is cut without cutting the label backing. This makes it easier to remove the backing paper from the labels.

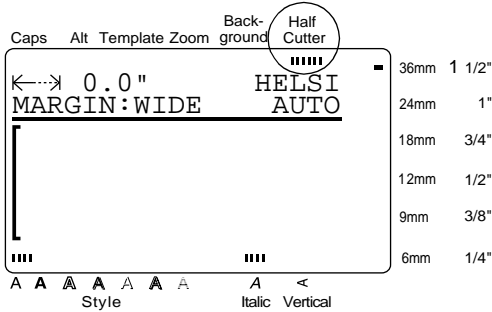

The following **CUT** settings are available:

- [ABC] [ABC]** **[BOTH]**
(both full and half cuts)
- [ABC] [ABC]** **[FULL]**
(full cut only)
- [ABC] : [ABC]** **[HALF]**
(half cut only)
- [ABC] [ABC]** **[OFF]**
(neither full nor half cuts)

1 Press **(Print)**.

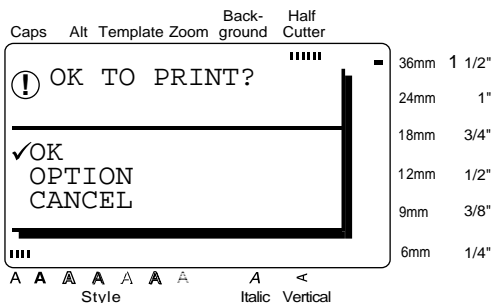

2 Press **↑** or **↓** to move **✓** beside **OPTION**.

NOTE
To return to the text without making any changes, press **(Print)** at any time.

3 Press **↵**.

NOTE

- ☞ To display the **OPTION** menu quickly, hold down **Code** and press **(Print)**.
- ☞ To return to the previous screen without keeping any changes, press **Cancel**.
- ☞ To return all functions in the **OPTION** menu to their default settings, hold down **Code** and press **(space bar)**.

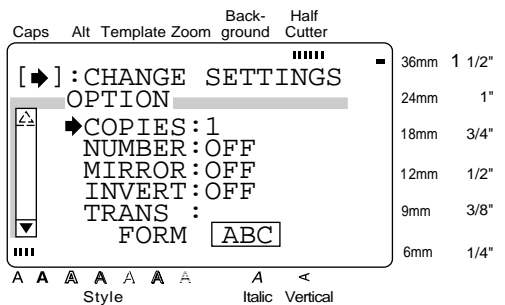

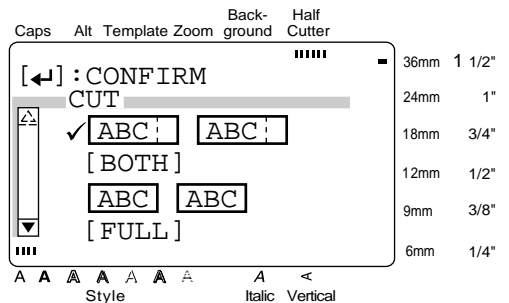

4 Press **→** or **↓** to move **→** beside **CUT**.

5 Press **↵**.



Ch. 3 Functions

6 Press  or  to move ✓ beside the desired setting.

NOTE

To select the default setting (**[ABC:]** **[ABC:]** **[BOTH]**), press (space bar).

7 Press  to confirm the setting and return to the **OPTION** menu.

To use SPLIT printing:

The **SPLIT** function enlarges the text and prints it on 2, 3 or 4 labels, which can be assembled to create extra-large labels.





Cut off the blank space on the bottom of the first label, then put the top and bottom parts together so that there is no break in the characters.

NOTE

If the labels are printed on transparent tape, they can be put together without being cut.

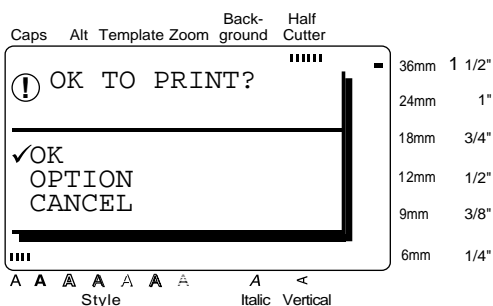
1 Press .





2 Press  or  to move ✓ beside **OPTION**.

NOTE

To return to the text without making any changes, press  at any time.

3 Press .



NOTE

To display the **OPTION** menu quickly, hold down  and press .

To return to the previous screen without keeping any changes, press .

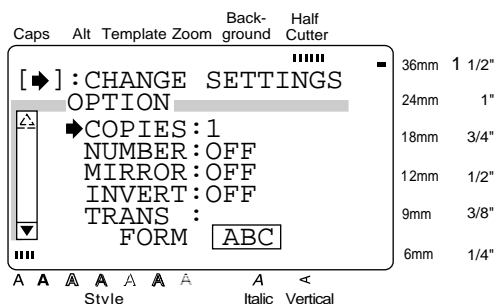

To return all functions in the **OPTION** menu to their default settings, hold down  and press (space bar).

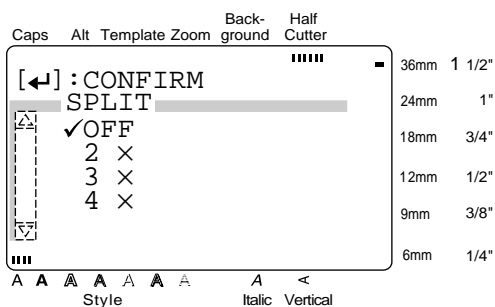

4 Press  or  to move → beside **SPLIT**.

5 Press .



6 Press  or  to move ✓ beside the desired setting.

NOTE

To select the default setting (**OFF**), press (space bar).

- Press  to apply the setting and return to the **OPTION** menu.

Setting display features

Setup ()



Pressing  displays four functions which let you change the general appearance of text shown on the display.

To change the **LINE NO.** setting:

This function allows you to select whether or not the number of the line currently containing the cursor is displayed during Zoom mode. (The line numbers are not displayed in WYSIWYG mode.)

- Press .

NOTE

To return all functions in the **SETUP** menu to their default settings, hold down  and press  (space bar).

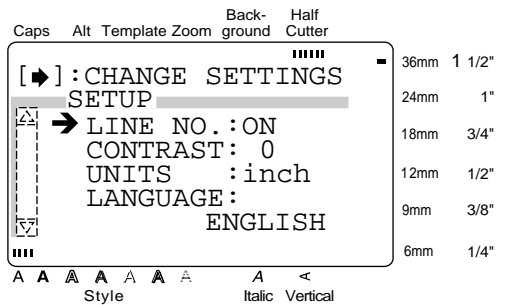

- Since  is already beside **LINE NO.**, press

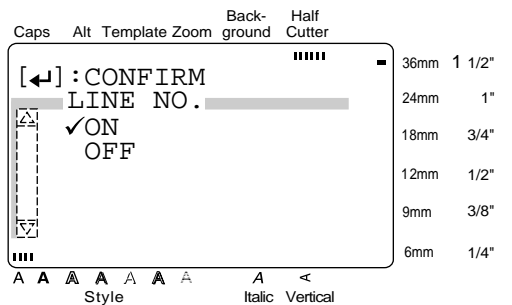

Ch. 3 Functions

- Press or to move ✓ beside the setting that you wish to select.

NOTE

To select the default setting, press (space bar).

- Press once to confirm the setting and return to the **SETUP** menu.
- Press again to apply the setting.

To change the CONTRAST setting:

The **CONTRAST** function enables you to make the LCD display lighter or darker.

- Press .

NOTE

To return all functions in the **SETUP** menu to their default settings, hold down and press (space bar).

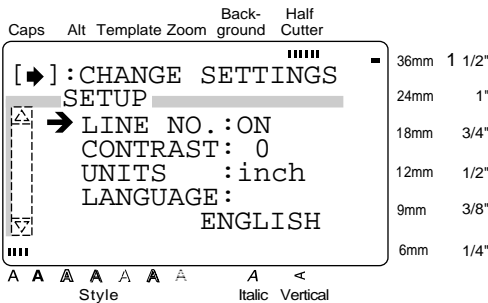

- Press or to move → beside **CONTRAST**.
- Press .

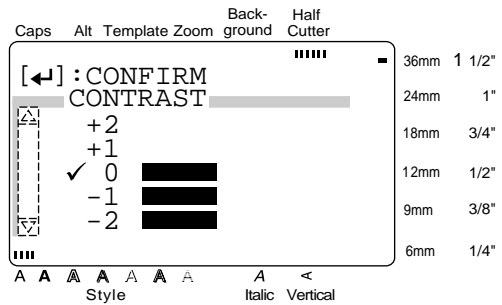

- Press or to move ✓ beside the setting that you wish to select.

NOTE

To select the default setting, press (space bar).

- Press once to confirm the setting and return to the **SETUP** menu.
- Press again to apply the setting.

To change the UNITS setting:



This function lets you choose the units used for displaying measurements.

- Press .

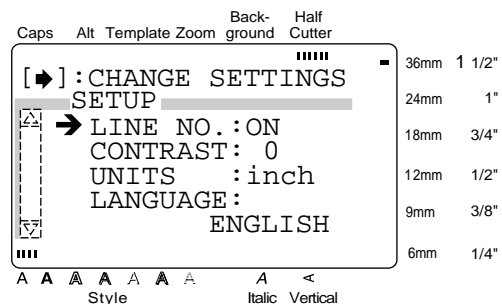

NOTE

To return all functions in the **SETUP** menu to their default settings, hold down and press (space bar).



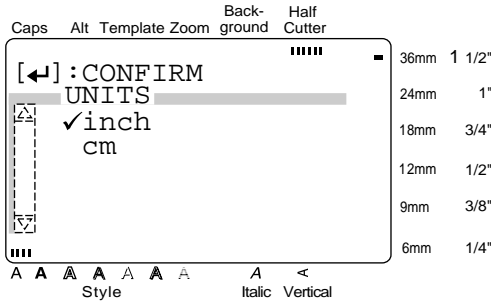

- 2 Press  or  to move → beside **UNITS**.
- 3 Press .



- 4 Press  or  to move ✓ beside the setting that you wish to select.

NOTE
To select the default setting, press (space bar).

- 5 Press  once to confirm the setting and return to the **SETUP** menu.
- 6 Press  again to apply the setting.



To change the LANGUAGE setting:

The **LANGUAGE** function allows you to select whether the menus, settings, and messages will appear in English or French.

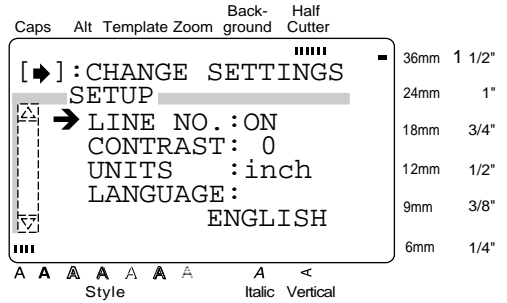

- 1 Press .

NOTE
To return all functions in the **SETUP** menu to their default settings, hold down  and press (space bar).



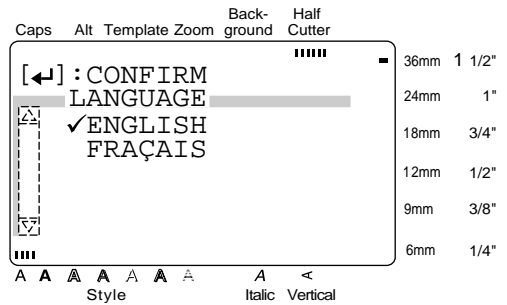

- 2 Press  or  to move → beside **LANGUAGE**.
- 3 Press .



- 4 Press  or  to move ✓ beside the setting that you wish to select.

NOTE
To select the default setting, press (space bar).

- 5 Press  once to confirm the setting and return to the **SETUP** menu.
- 6 Press  again to apply the setting.

Chapter 4

Using Labels and Stamps

Laminated tape

The backing from labels printed on laminated tapes can easily be removed if a half cut setting was used (refer to page 55). However, if a half cut setting was not used, the backing paper can be removed by using the enclosed lettering stick.

- 1 Hold the tape in your left hand, with the printed surface facing up, and hold the lettering stick in your right hand.
- 2 Pass the tape halfway through the long narrow hole in the stick.
- 3 Turn the stick three quarters of a turn towards you and pull the stick away from you as shown below.
- 4 Peel off the label backing.

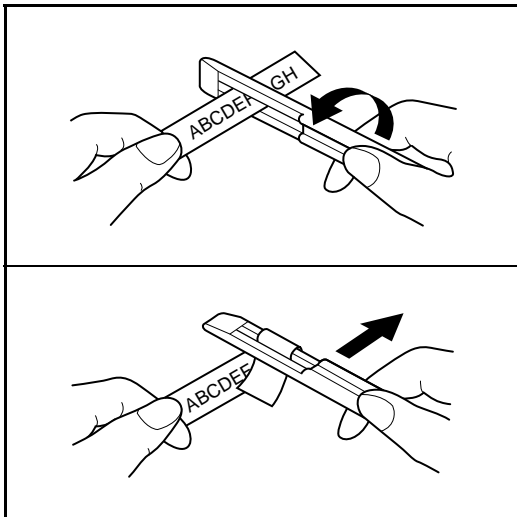

Stamp film

In addition to labels, your P-touch can be used to make custom, pre-inked stamps for various uses (optional stamp kit required). Simply design your own customized stamps using one of the pre-formatted stamp templates, and then affixing the printed stamp stencil to a self-inking stamp film holder.

- 1 Install a stamp film cassette and enter text into a pre-formatted stamp template. Refer to pages 41 through 45 for more details on using templates.
- 2 Print out the stamp stencil and remove its backing paper.
- 3 Remove the frame from around the stamp holder ink pad, one end at a time, and then remove the protective seal covering the ink pad.

NOTE	
☞	If the stamp holder already contains a stamp film, hold the stamp over a piece of scrap paper and remove the stamp frame by pulling it off, one end at a time. Then, slowly peel off the stamp film. Be careful that the ink does not splatter.
☞	Keep the stamp film holder out of the reach of children.
☞	Avoid getting ink in your eyes or mouth. If ink gets in your eyes or mouth, immediately wash it with fresh water for several minutes and consult a doctor.
☞	Keep ink off skin, clothes and important papers. Immediately use soap to wash skin that has come in contact with ink. Even washing may not remove all ink.

- 4 With the glossy side of the stamp film facing up, align one end of the stamp film with the slit in the side of the stamp holder.

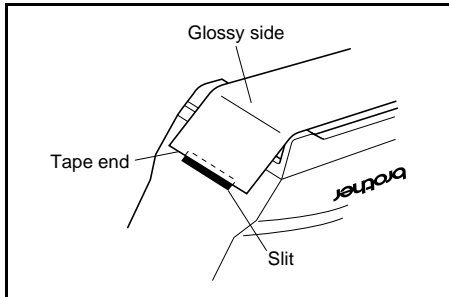

- 5 Hold the end of the stamp film in place with your thumb, then pass the stamp film through the guides while pulling it tight.

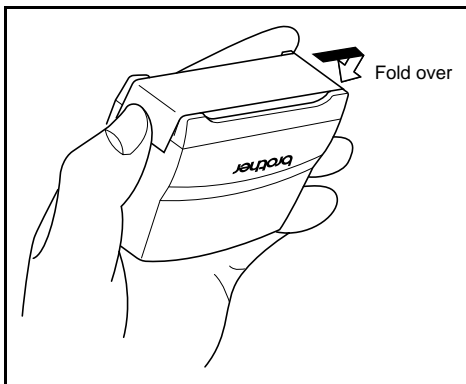

- 6 Fold the other end of the stamp film over the other side of the stamp holder and hold it in place with your finger.

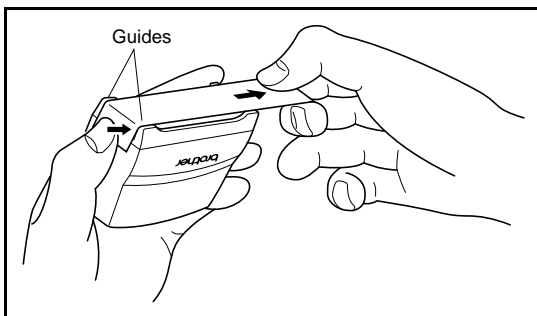



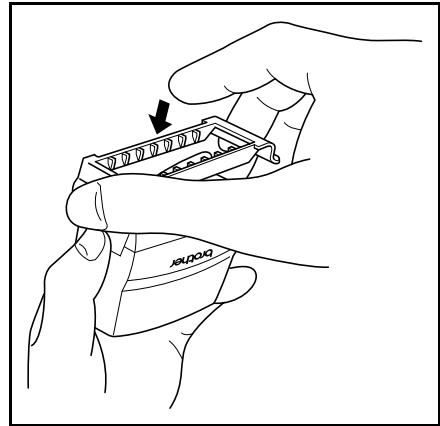











- 7 Fit the frame over the stamp film, and then push the frame into place.











- 8 Insert the stamp holder straight into the cap.











NOTE	
☞	Be sure that the cap correctly covers the stamp in order to prevent ink spills.
☞	When the stamp is not being used, firmly cover it with the cap and always store it standing up with the stamp facing downward. Do not leave the stamp laying on its side or leaning.
☞	Store stamp film holders and stamp film cassettes in a location where they are not exposed to high temperatures, high humidity or direct sunlight.

ERROR MESSAGE LIST

ERROR MESSAGE	CAUSE	SOLUTION
ALL FILES ARE USED	<ul style="list-style-type: none"> This message appears if there are no empty files available when NEW or SAVE AS (FILE menu) is selected. 	<ul style="list-style-type: none"> Delete unneeded files to make space for new ones.
BARCODE MUST START & END WITH A, B, C OR D	<ul style="list-style-type: none"> This message appears if A, B, C or D has not been entered at the beginning and end of a barcode with the CODABAR protocol. 	<ul style="list-style-type: none"> Enter A, B, C or D at the beginning and end of the barcode.
BUFFER EMPTY	<ul style="list-style-type: none"> This message appears if no text has been typed in when you press  or , when you hold  and press  or , or when you press  after selecting BLOCK, LINE or CHARACTER (FRAME or SHADING menus), or SAVE AS or SAVE (FILE menu). 	<ul style="list-style-type: none"> Type in some text before trying to perform any of these operations.
BUFFER FULL	<ul style="list-style-type: none"> This message appears if enough text has already been entered to fill the buffer, and you try to paste in text or add a character, a space, a new line, a new block, a symbol, an accented character or a barcode. This message appears if enough text has already been entered to fill the buffer, and you press , , , , , ,  or . 	<ul style="list-style-type: none"> Delete some of the text before trying to add any more. Delete some of the text before trying to change the text format.
CAN'T FIND FILE	<ul style="list-style-type: none"> This message appears if a file with the entered file name cannot be found. 	<ul style="list-style-type: none"> Search for a different file name.
CLOSE CASSETTE COVER	<ul style="list-style-type: none"> This message appears if the tape compartment cover is open. 	<ul style="list-style-type: none"> Close the compartment cover.
CUTTER ERROR TURN POWER OFF, THEN ON AGAIN	<ul style="list-style-type: none"> This message appears if the cutter did not operate correctly. 	<ul style="list-style-type: none"> Turn off the P-touch, and then turn it on again.
EEPROM ERROR TURN POWER OFF, THEN ON AGAIN	<ul style="list-style-type: none"> This message appears if there is a problem with the machine's memory. 	<ul style="list-style-type: none"> Contact your service representative.
HALF CUT ERROR TURN POWER OFF, THEN ON AGAIN	<ul style="list-style-type: none"> This message appears if the half cutter did not operate correctly. 	<ul style="list-style-type: none"> Turn off the P-touch, and then turn it on again.

ERROR MESSAGE LIST

ERROR MESSAGE	CAUSE	SOLUTION
INCORRECT NUMBER OF DIGITS FOR BARCODE TYPE	<ul style="list-style-type: none"> This message appears if the barcode data that is entered contains the incorrect number of digits for the selected barcode protocol. 	<ul style="list-style-type: none"> Enter barcode data that contains the correct number of digits.
INCORRECT OPERATION FOR NUMBERING FUNCTION	<ul style="list-style-type: none"> This message appears if characters in different lines or blocks are selected as a numbering field (NUMBER function on the OPTION menu). This message appears if a barcode is selected together with other characters as a numbering field (NUMBER function on the OPTION menu). This message appears if more than five characters are selected as the numbering field (NUMBER function on the OPTION menu). 	<ul style="list-style-type: none"> Adjust the numbering field so that it only contains characters within a single line of a single block. Select either the barcode or the characters alone as the numbering field. Limit the numbering field to five characters.
INSERT CASSETTE	<ul style="list-style-type: none"> This message appears if no tape cassette is installed when you try to print text. 	<ul style="list-style-type: none"> Install a tape cassette and try again.
LENGTH LIMIT	<ul style="list-style-type: none"> This message appears if you try to paste in text or add a character, a space, a new block, a symbol, an accented character, a barcode or a frame/shading, causing the text to exceed the 4' (1.2-meter) limit. This message appears if you press  after changing a label format function on the FORMAT menu, or press  ,  ,  ,  ,  ,  or  , causing the text to exceed the 4' (1.2-meter) limit. This message appears if you try to print using the NUMBER (numbering) function, causing the text to exceed the 4' (1.2-meter) limit. This message appears if you press  to delete text, causing the text to exceed the 4' (1.2-meter) limit. This message appears if you try to recall a text file from the memory, causing the text to exceed the 4' (1.2-meter) limit. 	<ul style="list-style-type: none"> Delete some of the text or reduce the character size before trying to add more text. Delete some of the text before trying to change the label or text formats. Delete some of the text or reduce the character size. Delete some of the text or reduce the character size. Delete some of the text before recalling it.

ERROR MESSAGE	CAUSE	SOLUTION
LIMIT EXCEEDED SET BETWEEN 4.0-30.0 cm	<ul style="list-style-type: none"> This message appears if the set label length (LENGTH function on the FORMAT menu) is not within the range 4.0 to 30.0 cm. 	<ul style="list-style-type: none"> Type in a label length that is within the specified range.
LIMIT EXCEEDED SET BETWEEN 1.6-11.8 inch	<ul style="list-style-type: none"> This message appears if the set label length (LENGTH function on the FORMAT menu) is not within the range 1.6 to 11.8 inches. 	<ul style="list-style-type: none"> Type in a label length that is within the specified range.
LINE LIMIT	<ul style="list-style-type: none"> This message appears if you press  to delete text or press  to add a new line, causing the number of lines in a block to exceed the maximum possible for the installed tape. This message appears if you try to recall a file or print text which contains more lines than the maximum possible for the installed tape. 	<ul style="list-style-type: none"> Adjust the number of lines so that the block will not have more than the maximum possible. Reduce the number of lines or install a wider tape.
MAX 5 BARCODES	<ul style="list-style-type: none"> This message appears if five barcodes already exist when you press . 	<ul style="list-style-type: none"> Limit the number of barcodes in the text to five.
MAX 5 BLOCKS	<ul style="list-style-type: none"> This message appears if five blocks already exist when you hold down  and press . 	<ul style="list-style-type: none"> Limit the number of blocks in the text to five.
MAX 10 LINES	<ul style="list-style-type: none"> This message appears if ten lines have already been entered in a block of text when you press . This message appears if you press  to delete text, causing the number of lines in a block to exceed the ten-line limit. 	<ul style="list-style-type: none"> Limit the number of lines in the text block to ten or hold down  and press  to create a new block. Adjust the number of lines so that the block will not have more than ten lines.
MAX 30 CHRS	<ul style="list-style-type: none"> This message appears if more than 30 characters are selected when you press . 	<ul style="list-style-type: none"> Limit the number of characters that will be copied and pasted to 30.
MAX 50 CHRS	<ul style="list-style-type: none"> This message appears if you try to add more than 50 underlines, frames and shadings. 	<ul style="list-style-type: none"> Limit the number of underlines, frames and shadings in the text to 50.

ERROR MESSAGE LIST

ERROR MESSAGE	CAUSE	SOLUTION
MEMORY FULL	<ul style="list-style-type: none"> This message appears if you try to store a message that is too large to fit in the available memory space (maximum of 3,000 characters). 	<ul style="list-style-type: none"> Delete an unwanted file to make space for the new one.
MIN 4 DIGITS	<ul style="list-style-type: none"> This message appears if less than the minimum four digits are entered as the barcode data. 	<ul style="list-style-type: none"> Enter a minimum of four digits before pressing .
NO FILES	<ul style="list-style-type: none"> This message appears if no files are stored in the memory when you try to recall or delete one. 	<ul style="list-style-type: none"> Store a text file before trying to recall or delete one.
NO PRINTING TEMPLATES ON IRON-ON OR LETTERING TAPE	<ul style="list-style-type: none"> This message appears if you try to print a template on iron-on or lettering tape. 	<ul style="list-style-type: none"> Install a tape cassette that does not contain iron-on or lettering tape.
RAM PROBLEM	<ul style="list-style-type: none"> This message appears if there is a problem with the machine's memory. 	<ul style="list-style-type: none"> Contact your service representative.
ROM PROBLEM	<ul style="list-style-type: none"> This message appears if there is a problem with the machine's memory. 	<ul style="list-style-type: none"> Contact your service representative.
SET 3/8" TAPE	<ul style="list-style-type: none"> This message appears if a 3/8" (9-mm)-wide tape cassette is not installed when printing a label created using a template for 3/8" (9-mm)-wide tape. 	<ul style="list-style-type: none"> Install a 3/8" (9-mm)-wide tape cassette.
SET 1/2" TAPE	<ul style="list-style-type: none"> This message appears if a 1/2" (12-mm)-wide tape cassette is not installed when printing a label created using a template for 1/2" (12-mm)-wide tape. 	<ul style="list-style-type: none"> Install a 1/2" (12-mm)-wide tape cassette.
SET 3/4" TAPE	<ul style="list-style-type: none"> This message appears if a 3/4" (18-mm)-wide tape cassette is not installed when printing a label created using a template for 3/4" (18-mm)-wide tape. 	<ul style="list-style-type: none"> Install a 3/4" (18-mm)-wide tape cassette.
SET 1" TAPE	<ul style="list-style-type: none"> This message appears if a 1" (24-mm)-wide tape cassette is not installed when printing a label created using a template for 1" (24-mm)-wide tape. 	<ul style="list-style-type: none"> Install a 1" (24-mm)-wide tape cassette.
SET 1 1/2" TAPE	<ul style="list-style-type: none"> This message appears if a 1 1/2" (36-mm)-wide tape cassette is not installed when printing a label created using a template for 1 1/2" (36-mm)-wide tape. 	<ul style="list-style-type: none"> Install a 1 1/2" (36-mm)-wide tape cassette.





ERROR MESSAGE	CAUSE	SOLUTION
SET STAMP L	<ul style="list-style-type: none"> This message appears if an L-size stamp film cassette is not installed when printing a stamp created using a template for L-size stamp film. 	<ul style="list-style-type: none"> Install an L-size stamp film cassette.
SET STAMP M	<ul style="list-style-type: none"> This message appears if an M-size stamp film cassette is not installed when printing a stamp created using a template for M-size stamp film. 	<ul style="list-style-type: none"> Install an M-size stamp film cassette.
SYSTEM ERROR	<ul style="list-style-type: none"> This message appears if there is a problem with the machine's software. 	<ul style="list-style-type: none"> Contact your service representative.
TAPE END. CHANGE TAPE CASSETTE	<ul style="list-style-type: none"> This message appears if the end of the tape in the cassette has been reached. 	<ul style="list-style-type: none"> Replace the tape cassette.
TEXT TOO HIGH	<ul style="list-style-type: none"> This message appears if the height of the text is larger than the width of the installed tape. 	<ul style="list-style-type: none"> Reduce the number of lines in the text, reduce the size of the characters, or install a tape with a greater width.
TEXT TOO LONG	<ul style="list-style-type: none"> This message appears if the length of the text is longer than the label length that has been set. This message appears if the text typed into a line in a template (TEMPLATE function) exceeds the preset length. 	<ul style="list-style-type: none"> Delete some of the text, reduce the character width, or increase the set label length. Enter fewer characters.
UNABLE TO PERFORM THIS OPERATION HERE	<ul style="list-style-type: none"> This message appears if the cursor is located in a barcode mark when you try to paste in text or add a character, a space, a new line, a new block, a symbol or an accented character. This message appears if the cursor is located in a barcode mark when you press <input type="text" value="Font"/> , <input type="text" value="Size"/> , <input type="text" value="Width"/> , <input type="text" value="Style"/> , <input type="text" value="Italic"/> , <input type="text" value="A / A"/> or <input type="text" value="Vert"/> . 	<ul style="list-style-type: none"> Move the cursor or delete the barcode before trying to add any more text. Move the cursor or delete the barcode before trying to change the text format.

TROUBLESHOOTING

Problem	Solution
<p>(1) The display stays blank after you have turned on the machine, or abnormal characters are displayed.</p>	<ul style="list-style-type: none"> ● Check that the power supply cord is connected. ● Reset the machine by turning it off, and while holding down Code and R, turning the machine back on. <p>☞ The text and formats in the display and all text files stored in the memory are erased.</p>
<p>(2) The text shown in the display cannot be read.</p>	<ul style="list-style-type: none"> ● Use the Zoom mode to zoom in on the text. Refer to page 21.
<p>(3) The machine does not print or the printed characters are blurred.</p>	<ul style="list-style-type: none"> ● Check that the tape cassette has been inserted properly. ● If the tape cassette is empty, replace it with a new one. ● Make sure that the tape compartment cover has been closed.
<p>(4) The text is printed on striped tape.</p>	<ul style="list-style-type: none"> ● You have reached the end of the tape in the cassette. Replace it with a new one.

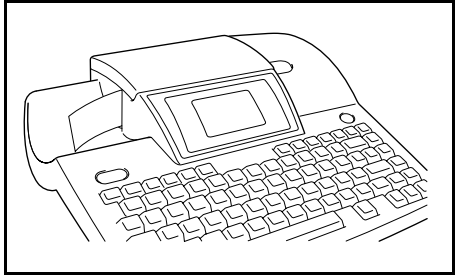
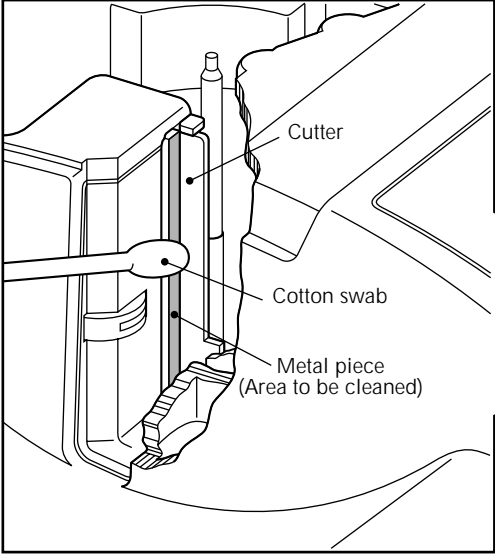
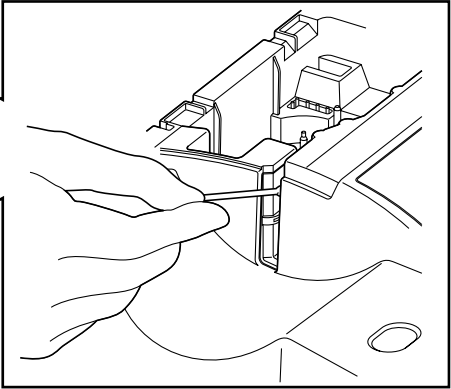
Problem	Solution
<p>(5) A blank horizontal line appears through the text in the printed label.</p>	<ol style="list-style-type: none"> 1 Turn off the machine. 2 Open the tape compartment cover, then remove the tape cassette if one is installed. The print head and rollers are located in the tape compartment. 3 Print head: Use a dry cotton swab to gently wipe up and down along the print head. <div data-bbox="765 452 1212 780" data-label="Image"> <p>A line drawing showing a hand holding a cotton swab and wiping the print head of a label printer. The print head is labeled 'Print head'.</p> </div> <p>Rollers: Use a dry cotton swab to wipe up and down along each roller while rotating them with your finger.</p> <div data-bbox="765 944 1212 1340" data-label="Image"> <p>A line drawing showing a hand using a cotton swab to clean the rollers of a label printer. The print head is labeled 'Print head', the rollers are labeled 'Rollers', and the cotton swab is labeled 'Cotton swab'.</p> </div> <ol style="list-style-type: none"> 4 Install a tape cassette, close the tape compartment cover, and then try printing again. 5 If a blank streak still appears in the printed label, repeat steps 2 through 4 using a cotton swab dipped in isopropyl (rubbing) alcohol. <p>If none of the above works, contact your service representative.</p>

TROUBLESHOOTING

Problem	Solution
<p>(6) The tape is not ejected correctly after being automatically cut.</p>	<ul style="list-style-type: none"> ● Turn off the machine, open the tape compartment cover, and remove the tape cassette if one is installed.  <ul style="list-style-type: none"> ● Using a cotton swab dipped in isopropyl (rubbing) alcohol, clean off the metal piece in the exit slot to the left of cutter.  
<p>(7) The machine has “locked up” (i.e., nothing happens when a key is pressed).</p>	<ul style="list-style-type: none"> ● Reset the machine by turning it off, and while holding down  and , turning the machine back on. <p> All text and formats in the display and all text files stored in the memory will be erased.</p>
<p>(8) After turning on the P-touch, the message “BACKUP MEMORY CLEARED” appears and all of the files in the memory are lost.</p>	<ul style="list-style-type: none"> ● The internal backup battery is low. Contact your nearest service representative.

MACHINE SPECIFICATIONS

HARDWARE

Power supply:	Input AC 120 V 60Hz (Auto power off if no key is pressed within 30 minutes)
Input device:	Keyboard (77 keys)
LCD:	118 × 64 dots 21 indicators (with back light)
Print tape:	6 widths available: 1/4" (6 mm) 3/8" (9 mm) 1/2" (12 mm) 3/4" (18 mm) 1" (24 mm) 1 1/2" (36 mm)
Print head:	384 dots (high)/360 dpi (resolution)
Tape cutter:	Auto full cutter Auto half cutter
Dimensions:	13.19" × 12.28" × 3.98" (335 × 312 × 101 mm)
Weight:	5.51 lbs. (2.5 kg)

SOFTWARE

Character fonts:	10 built-in fonts (Helsinki, Brussels, US, San Diego, Florida, Calgary, Brunei Bold, Los Angeles, Bermuda Script, and Istanbul)
Character sizes:	AUTO plus 9 point sizes (6, 9, 12, 18, 24, 36, 48, 60, and 72 points)
Character styles:	9 built-in type styles (Normal, Bold, Outline, Solid, Shadow, Outline+Shadow, Stripe, Italic, and Vertical)
Buffer size:	Maximum 4' (1.2-meter) line of text Maximum 10 lines Maximum 5 blocks
Memory size:	Approximately 3,000 characters

MACHINE SPECIFICATIONS

Appendix

Appendix

Symbols ⇨ p. 17

The following symbols are available.







































Category															
PUNCTUATION	Symbol	•	+	×	÷	±	=	\	§	¶	®	©	™	¿	¡
	Number	1	2	3	4	5	6	7	8	9	10	11	12	13	14
	Symbol	@	#	&											
	Number	15	16	17											
BRACKETS	Symbol	[]	{	}	<	>	«	»						
	Number	18	19	20	21	22	23	24	25						
ARROWS	Symbol	→	←	↑	↓	➔	➜	↕	↕	↔	↔				
	Number	26	27	28	29	30	31	32	33	34	35				
UNITS	Symbol	°	\$	Fr	¥	f	£	DM	Pts	Kr	in	mm	cm	km	kg
	Number	36	37	38	39	40	41	42	43	44	45	46	47	48	49
	Symbol	gm	cc	ℓ	°F	°C	oz.	lb.	ft.	zł	Pf	€	¢		
	Number	50	51	52	53	54	55	56	57	58	59	60	61		
SPECIAL LETTERS	Symbol	ä	ø	ß	Š	ɑ	β	γ	δ	μ	Ω				
	Number	62	63	64	65	66	67	68	69	70	71				
NUMBERS	Symbol	1/2	1/3	1/4	1	2	3	4	5	6	7	8	9	0	±
	Number	72	73	74	75	76	77	78	79	80	81	82	83	84	85
	Symbol	-	+	0	1	2	3	4	5	6	7	8	9	±	-
	Number	86	87	88	89	90	91	92	93	94	95	96	97	98	99
	Symbol	+	0	1	2	3	4	5	6	7	8	9			
	Number	100	101	102	103	104	105	106	107	108	109	110			
GENERAL	Symbol	★	○	●	□	△	♣	♥	♠	♣	✕	+	!	♪	☹
	Number	111	112	113	114	115	116	117	118	119	120	121	122	123	124
	Symbol	Ⓜ	Ⓝ	≠	☐										
	Number	125	126	127	128										

Category																
WARNING 1	Symbol															
	Number	129	130	131	132	133	134	135	136	137	138	139	140	141	142	
	Symbol															
	Number	143	144	145	146	147	148	149	150	151	152	153	154	155	156	
	Symbol															
	Number	157	158													
WARNING 2	Symbol															
	Number	159	160	161	162	163	164	165	166	167	168	169	170	171	172	
	Symbol															
	Number	173	174	175	176	177	178	179	180	181	182	183	184	185	186	
	Symbol															
	Number	187	188	189	190	191	192	193	194	195	196	197	198	199	200	
	Symbol															
	Number	201	202	203	204	205										
WARNING 3	Symbol															
	Number	206	207	208	209	210	211	212	213	214	215	216	217	218	219	
	Symbol															
	Number	220	221	222	223	224	225	226	227	228	229	230	231	232	233	
	Symbol															
	Number	234	235	236	237	238	239	240	241	242	243	244	245	246		
GUIDANCE	Symbol															
	Number	247	248	249	250	251	252	253	254	255	256	257	258	259	260	
	Symbol															
	Number	261	262	263	264	265	266	267	268	269	270	271	272	273	274	
	Symbol															
	Number	275	276	277	278	279	280	281	282	283	284	285	286	287	288	
	Symbol															
	Number	289	290	291	292	293	294	295	296	297						

Appendix

Category															
TRAFFIC SIGN	Symbol														
	Number	298	299	300	301	302	303	304							
SIGNS	Symbol														
	Number	305	306	307	308	309	310	311	312	313	314	315	316	317	318
	Symbol														
	Number	319	320	321	322	323	324	325	326	327	328				
EVENT	Symbol														
	Number	329	330	331	332	333	334	335	336	337	338	339	340	341	342
	Symbol														
	Number	343	344	345	346	347	348	349	350	351	352				
ANIMALS	Symbol														
	Number	353	354	355	356	357	358	359	360	361	362	363	364		
PLANTS	Symbol														
	Number	365	366	367	368										
FOOD&DRINK	Symbol														
	Number	369	370	371	372	373	374	375	376	377	378	379	380	381	382
	Symbol														
	Number	383	384	385	386										
OFFICE	Symbol														
	Number	387	388	389	390	391	392	393	394	395	396	397	398	399	400
	Symbol														
	Number	401	402	403	404	405	406	407	408	409	410	411	412	413	414
	Symbol														
	Number	415	416	417	418	419	420								
SPORT	Symbol														
	Number	421	422	423	424	425	426	427	428	429	430	431	432	433	434
	Symbol														
	Number	435	436												

Appendix

Category											
MEDICAL	Symbol										
	Number	437	438	439	440						
TRANSPORTATION	Symbol										
	Number	441	442	443	444						
TOOL	Symbol										
	Number	445	446	447	448						
ASTRONOMICAL	Symbol										
	Number	449	450	451	452						
POINTING	Symbol										
	Number	453	454	455	456	457	458	459	460		
FISH	Symbol										
	Number	461	462								
INSECTS	Symbol										
	Number	463	464	465	466						
VIDEO	Symbol										
	Number	467	468	469	470	471	472	473	474	475	

Appendix

Special barcode characters ⇨ p. 18

The following special characters can only be added to barcodes created using protocols EAN128 and CODE128.

Value	Character	Value	Character	Value	Character
3	#	69	ENQ	87	ETB
4	\$	70	ACK	88	CAN
11	+	71	BEL	89	EM
28	<	72	BS	90	SUB
29	=	73	HT	91	ESC
30	>	74	LF	91	{
32	@	75	VT	92	FS
59	[76	FF	92	
60	\	77	CR	93	GS
61]	78	SO	93	}
62	^	79	SI	94	RS
63	_	80	DLE	94	~
64	NUL	81	DC1	95	US
64	`	82	DC2	95	DEL
65	SOH	83	DC3	96	FNC3
66	STX	84	DC4	97	FNC2
67	ETX	85	NAK	100	FNC4
68	EOT	86	SYN	102	FNC1

The following special characters can only be added to barcodes created using protocols CODE39 or CODABAR.

Value	Character
1	+
2	\$

Fonts ⇨ p. 24

The following fonts are available.

HELSINKI	<i>CALGARY</i>
BRUSSELS	BRUNEI BOLD
US	LOS ANGELES
SAN DIEGO	<i>BERMUDA SCRIPT</i>
FLORIDA	ISTANBUL

Sizes and widths ⇨ pp. 25–27

Samples of the available text sizes and widths are shown below.

Width Size	Wide	Medium	Narrow
72pt	ABC	ABC	ABC
60pt	ABC	ABC	ABC
48pt	ABC	ABC	ABC
36pt	ABC	ABC	ABC
24pt	ABC	ABC	ABC
18pt	ABC	ABC	ABC
12pt	ABC	ABC	ABC
9pt	ABC	ABC	ABC
6pt	ABC	ABC	ABC

Appendix

Type styles ⇨ p. 28

	Normal	Bold	Outline	Solid	Shadow	Outline + Shadow	Stripe
Helsinki	ABC	ABC	ABC	ABC	ABC	ABC	ABC
Brussels	ABC	ABC	ABC	ABC	ABC	ABC	ABC
US	ABC	ABC	ABC	ABC	ABC	ABC	ABC
San Diego	ABC	ABC	ABC	ABC	ABC	ABC	ABC
Florida	ABC	ABC	ABC	ABC	ABC	ABC	ABC
Calgary	<i>ABC</i>	<i>ABC</i>	<i>ABC</i>	<i>ABC</i>	<i>ABC</i>	<i>ABC</i>	<i>ABC</i>
Brunei Bold	ABC	ABC	ABC	ABC	ABC	ABC	ABC
Los Angeles	ABC	ABC	ABC	ABC	ABC	ABC	ABC
Bermuda Script	<i>ABC</i>	<i>ABC</i>	<i>ABC</i>	<i>ABC</i>	<i>ABC</i>	<i>ABC</i>	<i>ABC</i>
Istanbul	ABC	ABC	ABC	ABC	ABC	ABC	ABC

Framing and shading patterns ⇨ p. 32



The following frame and shading patterns are available.

Frame		Shading

Appendix

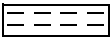

Background designs ⇨ p. 40

Samples of the available background designs are shown below.

OFF	ABC	ARABIC	ABC
 [SMALL]	ABC	TARTAN	ABC
 [LARGE]	ABC	ETHNIC	ABC
FLOORING	ABC	FLOWER	ABC
PLATE	ABC	GEOMETRI	ABC
TILE	ABC	GRADATION 1	ABC
MARBLES	ABC	GRADATION 2	ABC

Pre-set templates ⇨ p. 41

Samples of the available templates are shown below.

No.	Category	Template name	Tape width	Label length	Sample
1	ADDRESS	ADDRESS 1	1" (24 mm)	3.1" (8.0 cm)	Smith's Rent-A-Bike 29 Green Road Monterey, CA 00000 Tel: (012) 345-6789
2		ADDRESS 2	1" (24 mm)	3.1" (7.8 cm)	 Mike Smith 200 15th Avenue New York, NY 10000
3		ADDRESS 3	1" (24 mm)	4.1" (10.4 cm)	 LARRY SAMPSON VB Corporation MARKETING DEPT. 555 New Heaven, Miami, FL 33333 Tel: (012) 345-6789 Fax: (012) 345-6788
4		ADDRESS 4	1 1/2" (36 mm)	3.4" (8.6 cm)	 PETER A. ROBINS VB Corporation MARKETING DEPT. 555 New Heaven, Miami, FL 33333 Tel: (012) 345-6789 Fax: (012) 345-6788
5	EQUIPMENT	EQUIPMENT	1" (24 mm)	3.3" (8.4 cm)	PROPERTY OF SALES & MARKETING DIV. 
6	PLATE	PLATE	1 1/2" (36 mm)	7.3" (18.6 cm)	 CONFERENCE ROOM #1
7	NAMEPLATE	NAMEPLATE 1	3/4" (18 mm)	3.4" (8.6 cm)	Bill Reynolds ABC INTERNATIONAL INC.
8		NAMEPLATE 2	1 1/2" (36 mm)	3.9" (9.8 cm)	 LBI CORP. SALES & MARKETING DEPT. Mike Barkley
9		NAMEPLATE 3	3/4" (18 mm)	2.0" (5.2 cm)	 MIKE BARKEY MARKETING DEPT. LBI CORP.

Appendix

No.	Category	Template name	Tape width	Label length	Sample
10	SHOP	SALE	1 1/2" (36 mm)	9.7" (24.6 cm)	
11		PRICE 1	1" (24 mm)	2.2" (5.7 cm)	LABEL PRINTER \$249
12		PRICE 2	1" (24 mm)	4.3" (11.0 cm)	LABEL PRINTER \$249 → \$229
13	SIGN	SIGN	1 1/2" (36 mm)	4.5" (11.4 cm)	
14	FLOPPY	FLOPPY 1	1" (24 mm)	2.8" (7.0 cm)	
15		FLOPPY 2	1" (24 mm)	2.8" (7.0 cm)	
16		FLOPPY 3	1 1/2" (36 mm)	2.8" (7.0 cm)	PRICE LIST 1995-2000 Sales Div. June 27, 2000

No.	Category	Template name	Tape width	Label length	Sample
17	VIDEO	VHS 1	3/4" (18 mm)	5.5" (14.0 cm)	
18		VHS 2	3/4" (18 mm)	5.5" (14.0 cm)	
19		8mm 1	3/8" (9 mm)	2.9" (7.3 cm)	
20		8mm 2	1/2" (12 mm)	3.6" (9.2 cm)	
21		VHSC	3/4" (18 mm)	3.2" (8.1 cm)	
22	AUDIO	AUDIO 1	3/8" (9 mm)	3.5" (8.9 cm)	
23		AUDIO 2	3/8" (9 mm)	3.5" (8.9 cm)	
24		AUDIO 3	3/8" (9 mm)	3.5" (8.9 cm)	
25	SLIDE	SLIDE	1/2" (12 mm)	1.7" (4.2 cm)	
26	FILE	FILE 1	1 1/2" (36 mm)	7.9" (20.0 cm)	
27		FILE 2	1" (24 mm)	7.5" (19.0 cm)	

Appendix

No.	Category	Template name	Tape width	Label length	Sample	
28	STAMP	NORMAL L	STAMP L	4.4" (11.2 cm)	FAXED	
29		NORMAL M	STAMP M	4.0" (10.2 cm)	FAXED	
30		FRAMED L	STAMP L	4.4" (11.2 cm)	<table border="1"><tr><td>FAXED</td></tr></table>	FAXED
FAXED						
31		FRAMED M	STAMP M	4.0" (10.2 cm)	<table border="1"><tr><td>FAXED</td></tr></table>	FAXED
FAXED						
32		2LINE L	STAMP L	4.4" (11.2 cm)	RECEIVED Date: / /	
33		2LINE/ FRAME L	STAMP L	4.4" (11.2 cm)	<table border="1"><tr><td>RECEIVED Date: / /</td></tr></table>	RECEIVED Date: / /
RECEIVED Date: / /						
34	VERTICAL L	STAMP L	4.4" (11.2 cm)	LAXWD		
35	VERTICAL M	STAMP M	4.0" (10.2 cm)	LAXWD		

Template text styles ⇨ p. 43







Samples of the available template text styles are shown below.

CHAR. style	Sample	Font	Style	Italic
ORIGINAL	Bill Reynolds ABC INTERNATIONAL INC.	Template default		
ITALIC	<i>Bill Reynolds</i> <i>ABC INTERNATIONAL INC.</i>	Template default		ON
DYNAMIC	Bill Reynolds ABC INTERNATIONAL INC.	ISTANBUL	SOLID	OFF
CUTE	Bill Reynolds ABC INTERNATIONAL INC.	FLORIDA	OUTLINE	OFF
FORMAL	<i>Bill Reynolds</i> <i>ABC INTERNATIONAL INC.</i>	BRUSSELS	NORMAL	ON
ELEGANT	Bill Reynolds ABC INTERNATIONAL INC.	US	NORMAL	OFF
FREE	<i>Bill Reynolds</i> <i>ABC INTERNATIONAL INC.</i>	BERMUDA SCRIPT	OUTLINE + SHADOW	OFF
NATURAL	Bill Reynolds ABC INTERNATIONAL INC.	SAN DIEGO	NORMAL	OFF

Appendix

Text transformation styles ⇨ p. 54

Samples of the text transformation shapes are shown below.

	ABC
	A=B C
	A B C
	A B C
	A B C
	A B C

INDEX

A

Accented characters 15
All function 23
Alt key 15
Area key 22

B

BACK (background) function 40
Back Space key 21
Barcode key 18
Barcode special characters 20, 80
Blocks 16

C

Cancel key 14
Capital letters 15
Caps key 15
CH.DIG. parameter 19
Cleaning
 Print head 71
 Rollers 71
Clear key 21
CODABAR special characters 80
Code key 14
CODE128 special characters 80
CODE39 special characters 80
CONTRAST function 58
COPIES function 49
Copy & Paste key 24
Copying 24
Cursor keys 14
CUT function 55
Cutting tape 49, 55

D

Default settings
 BACK (background) function 40
 Font function 24
 H.ALI (horizontal alignment) function 39
 Italic function 29
 LENGTH function 37
 Line effects function 30
 MARGIN function 38
 PITCH function 40
 Size function 26
 Style function 28
 Vertical function 31

 Width function 27
Deleting
 Display 21
 Files 48
 Text 21
Display settings 57
Displaying
 Areas of text 14
 Enlargements 21

E

EAN128 special characters 80
Enter key 14, 16
Error messages 65

F

Feed & Cut key 49
FILE menu 44, 46
Font function 24
Format key 36
FORMAT menu 36
Formatting
 Label 36
 Text 24
Frame/Shading function 32
FRAME/SHADING menu 32
Framing 32

H

H.ALI (horizontal alignment) function 38

I

Image key 49
Indicators
 Alt 15
 Background 41
 Caps 15
 Half Cutter 55
 Italic 29
 Style 28
 Template 41
 Vertical 31
 Zoom 21
INVERT function 53
Italic function 29

L

Label length 36
LANGUAGE function 59
LENGTH function 36
Line effects function 30
LINE NO. function 57
Lines 16

M

MARGIN function 37
MENU menu 43
MIRROR function 52
Multiple copies 49

N

New Block function 16
NUMBER (numbering) function 50

O

OPTION menu 50

P

PARAMETER menu 19
Pasting 24
Pictures 17, 76
PITCH function 39
Previewing 49
Print key 49
Printing
 Identification labels 44
 Stamps 44
 Template labels 44
PROTO parameter 19
PROTOCOL menu 19
Punctuation marks 15, 17, 76

R

Recalling
 Template text 48
 Text 47
Reversing
 Print 53
 Text 52

S

Saving
 Template text 44
 Text 46

Selecting
 Functions 14
 Settings 14
 Text 22, 23
Setup key 57
SETUP menu 57
Shading 32
Shift key 15
Signs 17, 76
Size function 25
Space bar 15
SPECIAL CHARA. menu 20
SPLIT function 56
Stamp films 62
Storing
 Template text 44
 Text 46
Strike out 30
Style function 28
STYLE menu 43
Styles
 Character 28
 Template 43
Symbol function 17, 76
SYMBOL menu 17

T

Tapes 62
Template function 41
TEMPLATE menu 41
TRANSFORMATION function 54

U

UNDER#S parameter 19
Underlining 30
UNITS function 58

V

Vertical function 31

W

Width function 27
WIDTH parameter 19
WYSIWYG mode 15

Z

Zoom key 21

ACCESSORIES

Obtain tape cassettes from your nearest authorized dealer.

Use only Brother TZ tapes with this machine. Brother cannot be held responsible for trouble caused by the use of unauthorized supplies. Do not use tapes that do not have the  mark.

Stock No.	Description	QTY/PACKAGE	PRICE
1-1/2" (36-mm)-wide laminated tapes			
TZ-161	Black characters on clear tape	1	\$27.99
TZ-261	Black characters on white tape	1	\$27.99
TZ-661	Black characters on yellow tape	1	\$27.99
1" (24-mm)-wide laminated tapes			
TZ-151	Black characters on clear tape	1	\$23.99
TZ-251	Black characters on white tape	1	\$23.99
TZ-451	Black characters on red tape	1	\$23.99
TZ-651	Black characters on yellow tape	1	\$23.99
TZ-252	Red characters on white tape	1	\$23.99
TZ-354	Gold characters on black tape	1	\$26.99
TZ-355	White characters on black tape	1	\$26.99
3/4" (18-mm)-wide laminated tapes			
TZ-141	Black characters on clear tape	1	\$20.99
TZ-145	White characters on clear tape	1	\$20.99
TZ-241	Black characters on white tape	1	\$20.99
TZ-242	Red characters on white tape	1	\$20.99
TZ-243	Blue characters on white tape	1	\$20.99
TZ-344	Gold characters on black tape	1	\$24.99
TZ-345	White characters on black tape	1	\$23.99
TZ-441	Black characters on red tape	1	\$20.99
TZ-541	Black characters on blue tape	1	\$20.99
TZ-545	White characters on blue tape	1	\$23.99
TZ-641	Black characters on yellow tape	1	\$20.99
TZ-741	Black characters on green tape	1	\$20.99
TZ-B41	Black characters on fluorescent orange tape	1	\$24.99
TZ-M41	Black characters on clear (matte) tape	1	\$23.99
TZ-WB41	Black characters on Bugs Bunny tape	1	\$23.99
TZ-WT41	Black characters on Taz tape	1	\$23.99
TZ-WS41	Black characters on Tweety & Sylvester tape	1	\$23.99
1/2" (12-mm)-wide laminated tapes			
TZ-131	Black characters on clear tape	1	\$16.99
TZ-231	Black characters on white tape	1	\$17.99
TZ-232	Red characters on white tape	1	\$17.99
TZ-335	White characters on black tape	1	\$20.99
3/8" (9-mm)-wide laminated tapes			
TZ-121	Black characters on clear tape	1	\$14.99
TZ-221	Black characters on white tape	1	\$16.99

Stock No.	Description	QTY/PACKAGE	PRICE
TZ-325	White characters on black tape	1	\$18.99
TZ-421	Black characters on red tape	1	\$16.99
1/4" (6-mm)-wide laminated tapes			
TZ-111	Black characters on clear tape	1	\$12.99
TZ-211	Black characters on white tape	1	\$14.99
TZ-315	White characters on black tape	1	\$17.99

Special tapes

Stock No.	Description	QTY/PACKAGE	PRICE
TZ-SE4	Black characters on 3/4" (18-mm)-wide security tape	1	\$29.99
TZ-FA3	Blue characters on 1/2" (12-mm)-wide fabric tape	1	\$24.99

Stamp kit

Stock No.	Description	QTY/PACKAGE	PRICE
SK-LB	Stamp-making kit for Large stamp with black ink	1	\$39.99
SK-MB	Stamp-making kit for Medium stamp with black ink	1	\$37.99
SH-LB	Additional stamper for Large stamp with black ink	1	\$27.99
SH-MB	Additional stamper for Medium stamp with black ink	1	\$24.99